

Customer Information Sheet

IF IN DOUBT - ASK

©

NOT TO SCALE

THIRD ANGLE PROJECTION

ALL DIMENSIONS IN mm

SPECIFICATION:
 MATERIAL:
 CONTACT = STAINLESS STEEL
 FINISH:
 TIN OVER NICKEL.
 PACKAGING:
 15,000 PARTS IN TAPE AND REEL,
 9 REELS PACKED IN BOX

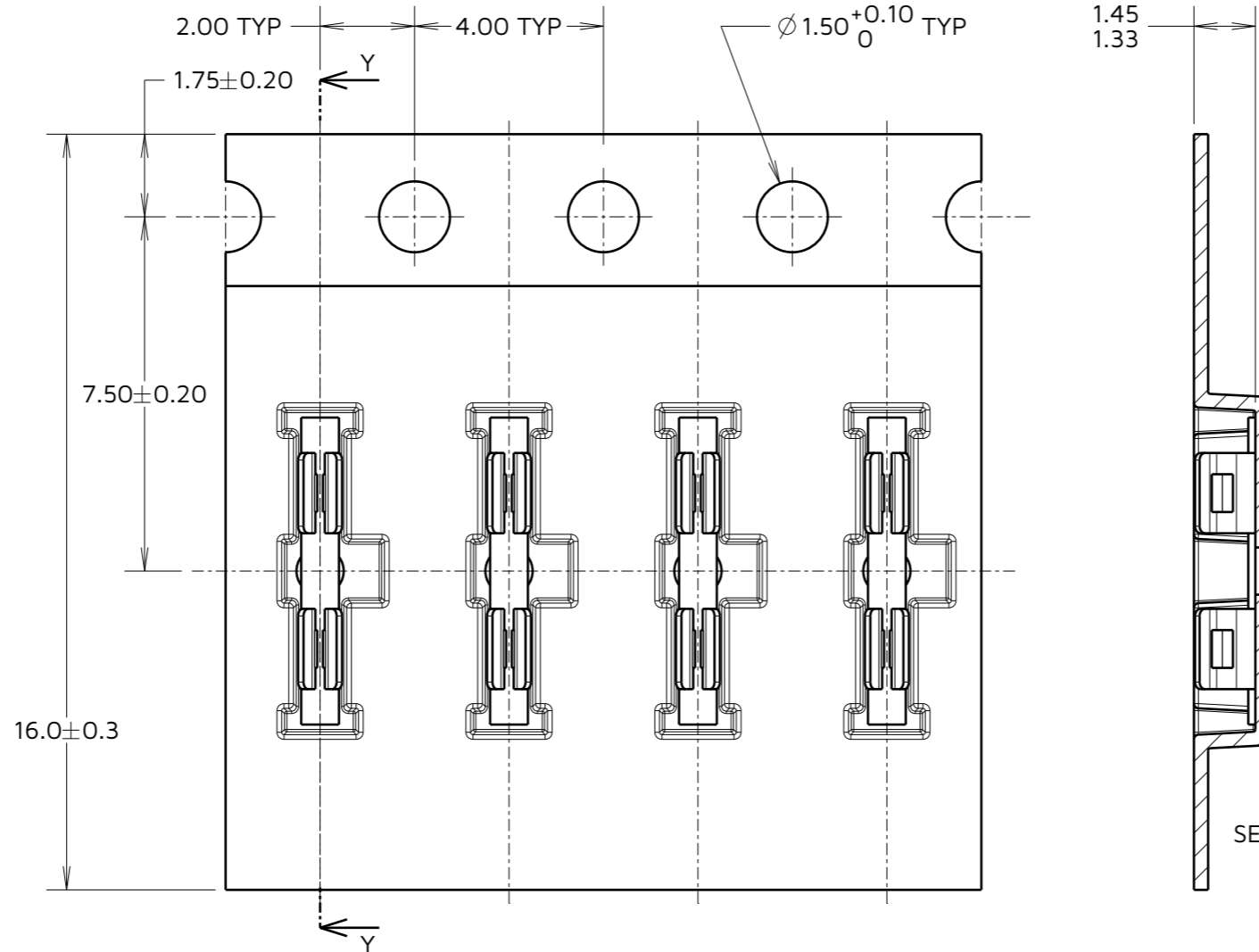
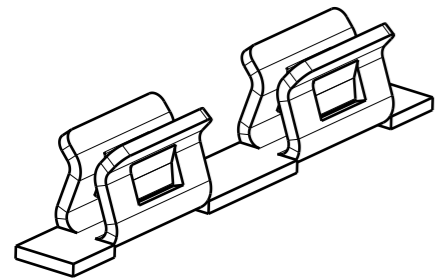

SECTION Y-Y

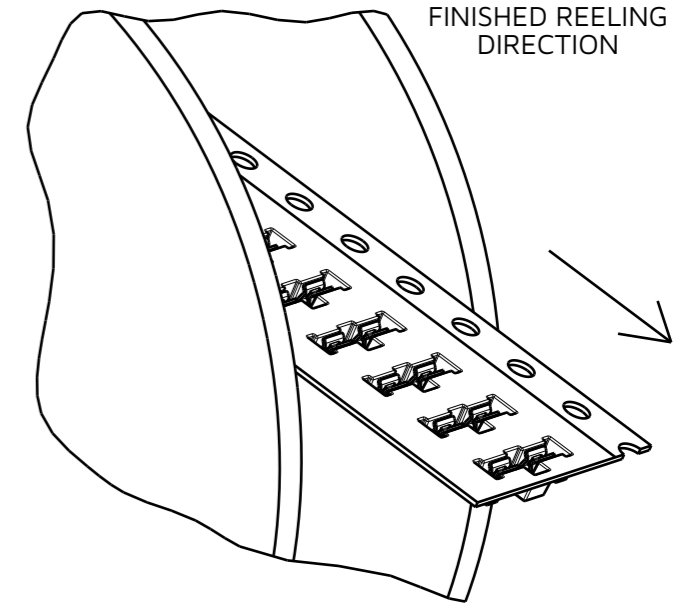

FINISHED REELING DIRECTION

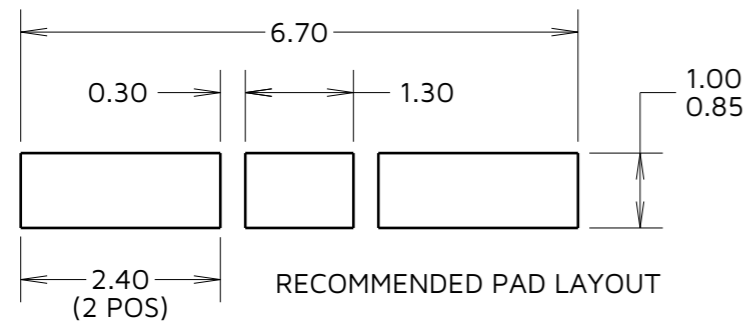

RECOMMENDED PAD LAYOUT

RECOMMENDED SHIELD CAN CUT OUT

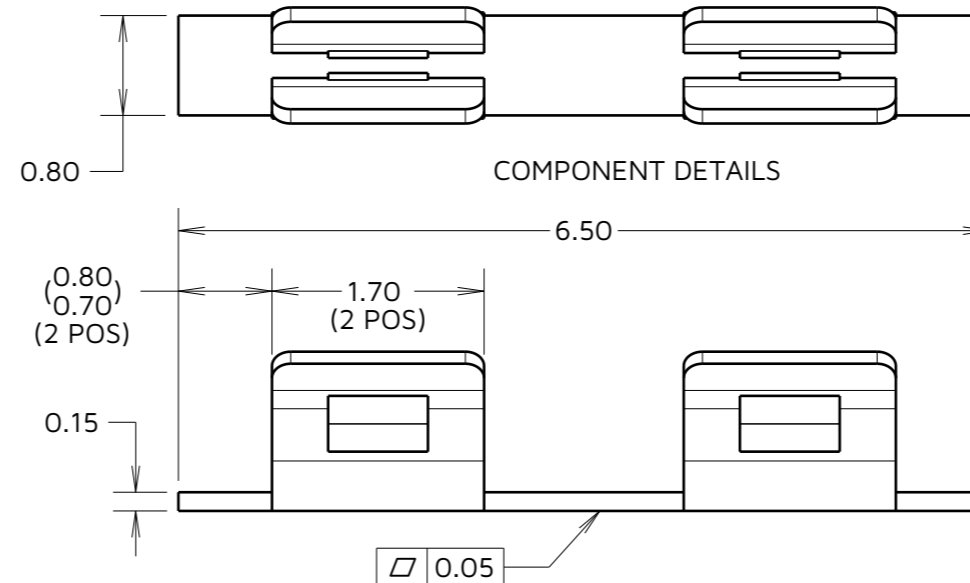
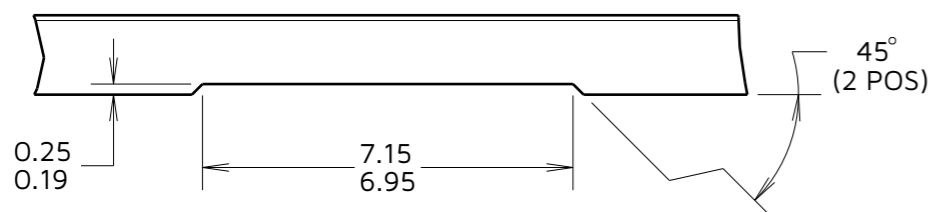

COMPONENT DETAILS

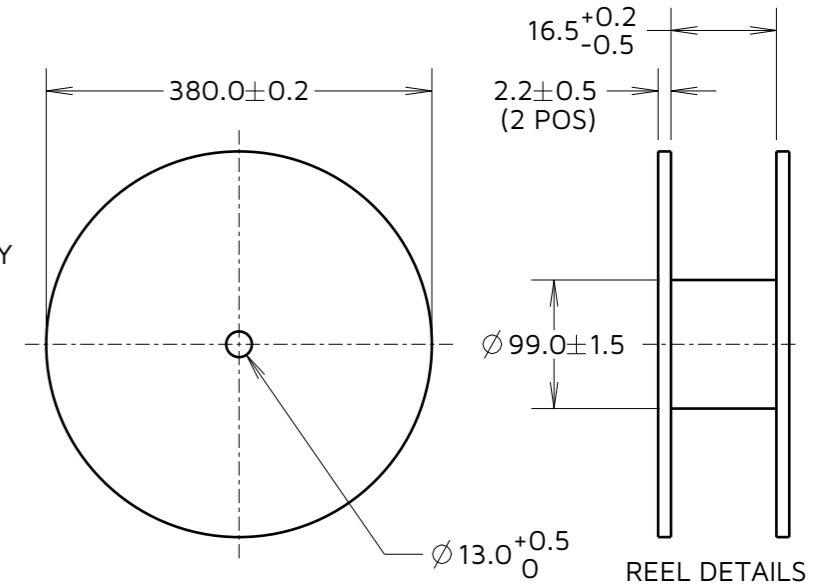

REEL DETAILS

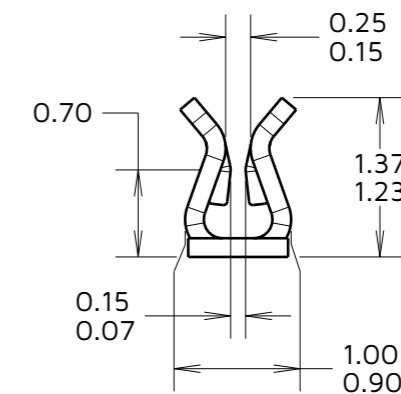

NOTES:
 1. MAXIMUM PERMISSABLE BURR IS 0.03mm MAX.
 2. FOR USE WITH 0.20 - 0.25mm THICK SHIELD CANS.

HARWIN

www.harwin.com

TOLERANCES
 X. = ±1mm
 X.X = ±0.50mm
 X.XX = ±0.20mm
 X.XXX = ±0.01mm
 ANGLES = ±5°
 UNLESS STATED

THIS DRAWING AND ANY INFORMATION OR DESCRIPTIVE MATTER SET OUT HEREON ARE CONFIDENTIAL AND COPYRIGHT PROPERTY OF THE HARWIN GROUP AND MUST NOT BE DISCLOSED, LOANED, COPIED OR USED FOR MANUFACTURING, TENDERING OR FOR ANY OTHER PURPOSE WITHOUT THEIR WRITTEN PERMISSION.

MATERIAL:
 STAINLESS STEEL

TITLE:
 SURFACE MOUNT RFI SHIELD CLIP IN TAPE AND REEL

DRAWING NUMBER:
 S0991-46R

SHT
 2 OF 2

MJ	6	11.10.24	34959
NAME	ISS.	DATE	CN/CO
APPROVED:		M. JELLEY	
CHECKED:		A. BOXALL	
DRAWN:		S.BENNETT	