

Customer Information Sheet

IF IN DOUBT - ASK

©

NOT TO SCALE

THIRD ANGLE PROJECTION

ALL DIMENSIONS IN mm

SPECIFICATIONS:

MATERIAL:
 HOUSING = GLASS-FILLED PPS, UL94V-0, BLACK
 CONTACT CLIP = BERYLLIUM COPPER
 CONTACT SHELL = BRASS
 JACKSCREW & CIRCLIP=STAINLESS STEEL
FINISH:
 01 = GOLD CLIP, TIN/LEAD SHELL
 05 = GOLD CLIP, GOLD SHELL
 42 = GOLD CLIP, 100% TIN SHELL
PACKING:
 TUBE

FOR COMPLETE SPECIFICATION, SEE COMPONENT SPECIFICATION CO05XX (LATEST ISSUE)

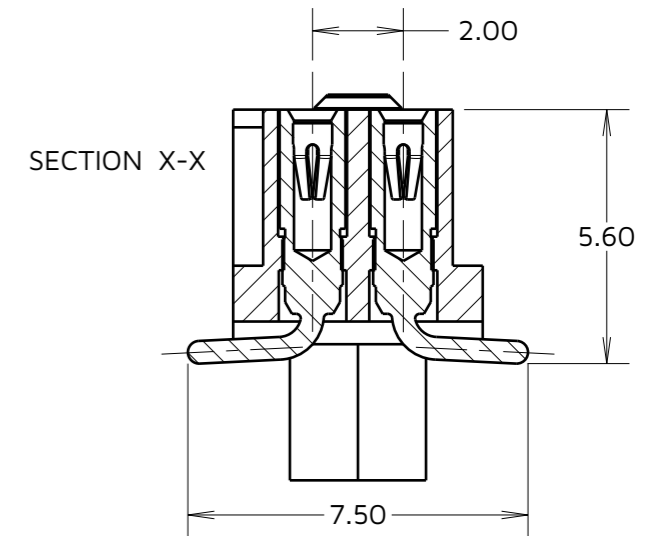
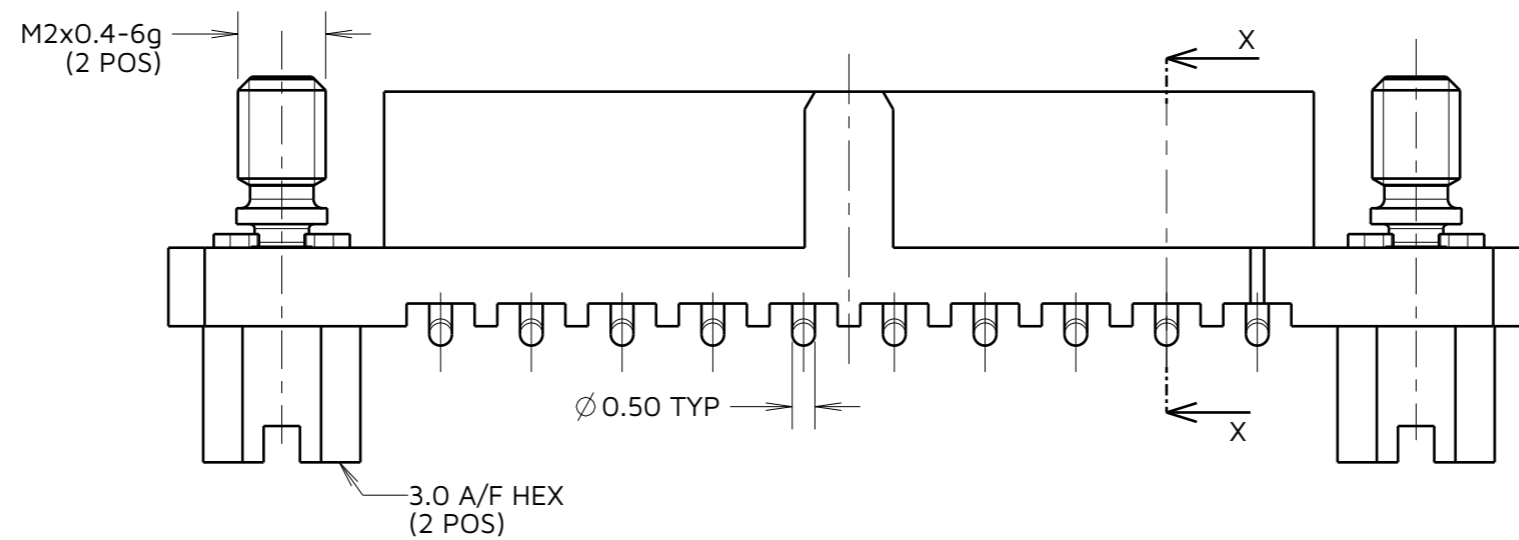
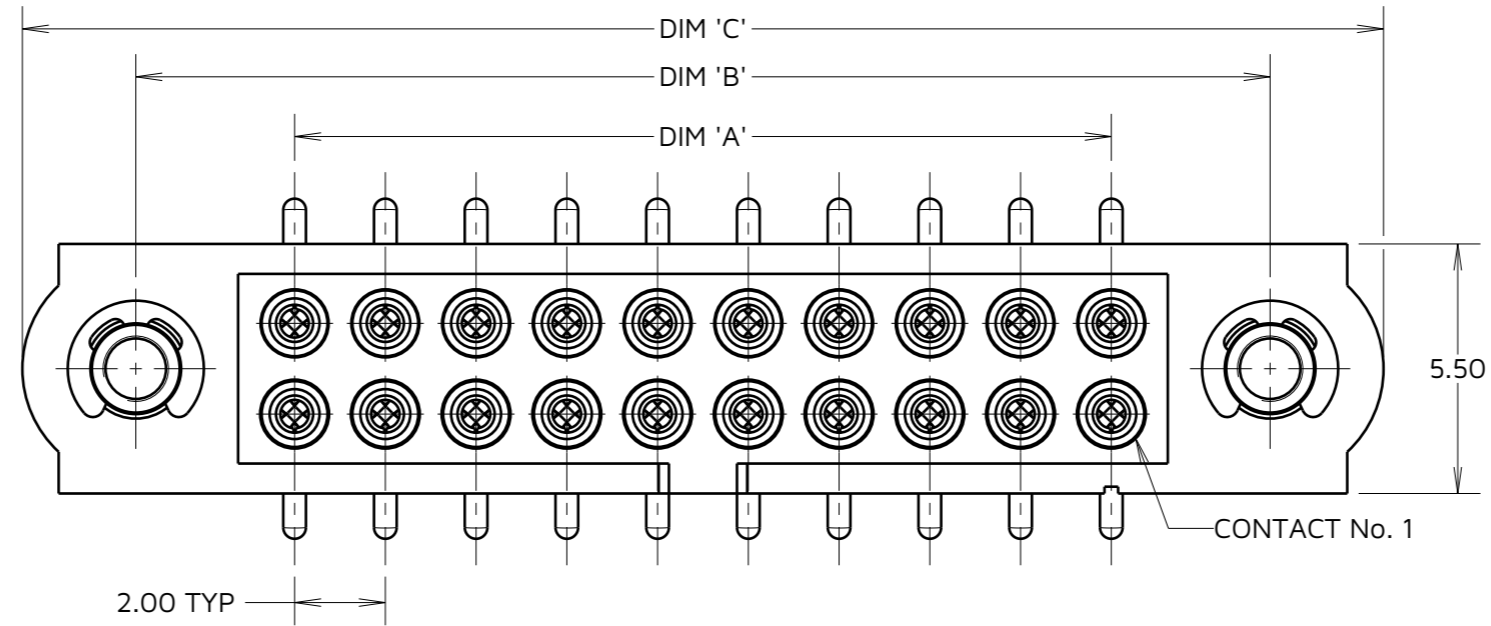

PART No.	WEIGHT (g)
M80-40204XX	1.01
M80-40206XX	1.15
M80-40208XX	1.29
M80-40210XX	1.43
M80-40212XX	1.57
M80-40214XX	1.72
M80-40216XX	1.86
M80-40218XX	2.00
M80-40220XX	2.14
M80-40222XX	2.28
M80-40224XX	2.42
M80-40226XX	2.57
M80-40228XX	2.71
M80-40230XX	2.85
M80-40232XX	2.99
M80-40234XX	3.13
M80-40236XX	3.28
M80-40238XX	3.42
M80-40240XX	3.56
M80-40242XX	3.70
M80-40244XX	3.84
M80-40246XX	3.98
M80-40248XX	4.13
M80-40250XX	4.27

DIMENSION	CALCULATION
DIM 'A'	TOTAL No. OF CONTACTS - 2.00
DIM 'B'	TOTAL No. OF CONTACTS + 5.00
DIM 'C'	TOTAL No. OF CONTACTS + 10.0

EXAMPLE: CONNECTOR WITH 20 CONTACTS, GOLD CLIP AND 100% TIN SHELL, M80-4022042

DIM 'A' = 18.00mm, DIM 'B' = 25.00mm, DIM 'C' = 30.00mm

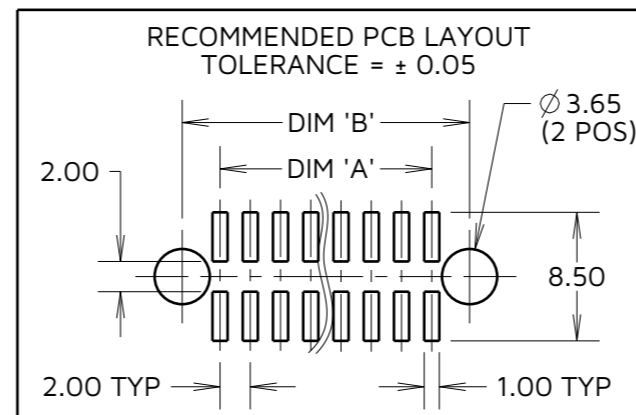

ORDER CODE:
M80-402XXXX

TOTAL No. OF CONTACTS
 04 TO 50
 (EVEN NUMBERS ONLY)

FINISH CODE _____

01 - GOLD CLIP, TIN/LEAD SHELL
 05 - GOLD CLIP, GOLD SHELL
 42 - GOLD CLIP, 100% TIN SHELL

MJ	2	18.12.24	35293
NAME	ISS.	DATE	CN/CO
APPROVED: M. JELLEY			
CHECKED: R. ALEXANDER			
DRAWN: B. M. KENT			

NOTES
 1. M80-40220XX IS SHOWN FOR ILLUSTRATION PURPOSES, SEE ORDER CODE FOR VARIANTS

HARWIN
 www.harwin.com

TOLERANCES
 X. = ±1mm
 X.X = ±0.50mm
 X.XX = ±0.20mm
 X.XXX = ±0.01mm
 ANGLES = ±5°
 UNLESS STATED

THIS DRAWING AND ANY INFORMATION OR DESCRIPTIVE MATTER SET OUT HEREON ARE CONFIDENTIAL AND COPYRIGHT PROPERTY OF THE HARWIN GROUP AND MUST NOT BE DISCLOSED, LOANED, COPIED OR USED FOR MANUFACTURING, TENDERING OR FOR ANY OTHER PURPOSE WITHOUT THEIR WRITTEN PERMISSION.

MATERIAL & FINISH:
 SEE ABOVE

TITLE:
 DATAMATE DIL FEMALE VERTICAL SMT CONNECTOR ASSEMBLY

DRAWING NUMBER:
M80-402XXXX

SHT 2 OF 2