

# Customer Information Sheet

IF IN DOUBT - ASK



NOT TO SCALE

THIRD ANGLE PROJECTION

ALL DIMENSIONS IN mm

**SPECIFICATIONS:**

**MATERIAL**

CARRIER = BRASS

CONTACT SHELL = BRASS

CONTACT CLIP = BERYLLIUM COPPER

**FINISH (CONTACTS):**

SEE ORDER CODE

FOR COMPLETE SPECIFICATION, SEE COMPONENT SPECIFICATION C006XX (LATEST ISSUE)

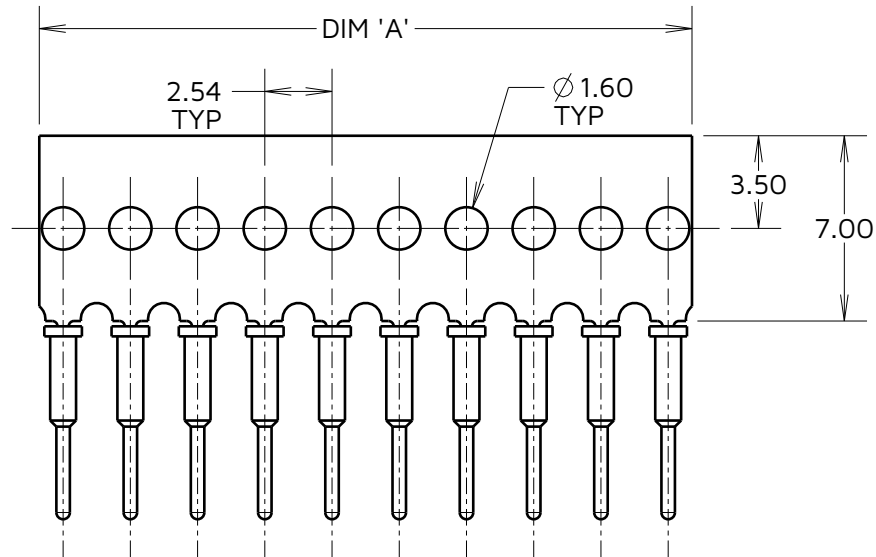
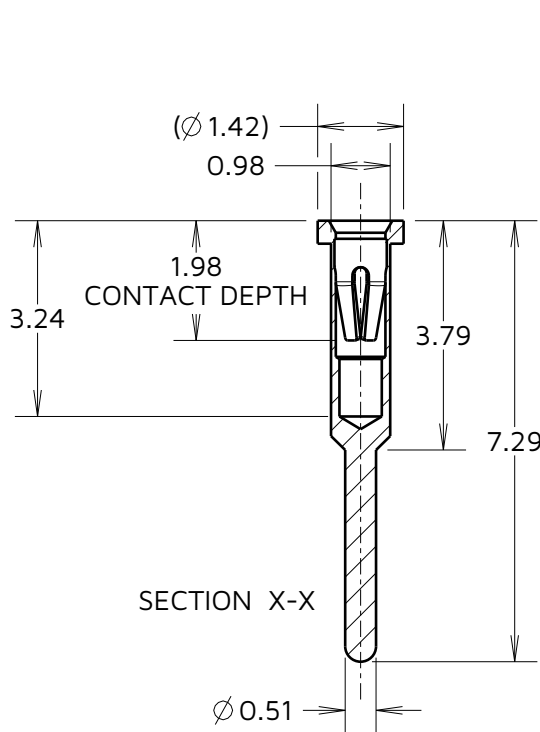
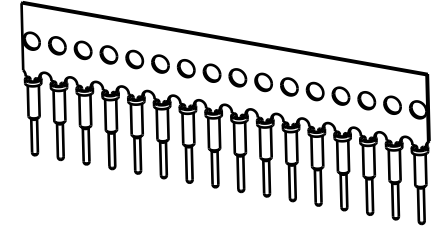

| PART No.    | DIM 'A' |
|-------------|---------|
| D01-97908XX | 19.6    |
| D01-97910XX | 24.7    |
| D01-97912XX | 29.7    |
| D01-97916XX | 39.9    |

**ORDER CODE:**  
**D01-979XXXX**

No. OF SOCKETS: 04 TO 32

FINISH:  
 01 = GOLD CLIP, TIN SHELL  
 05 = GOLD CLIP, GOLD SHELL

|           |      |           |       |
|-----------|------|-----------|-------|
| AY        | 7    | 11.09.24  | 34124 |
| NAME      | ISS. | DATE      | CN/CO |
| APPROVED: |      | A.YEOMANS |       |
| CHECKED:  |      | A.BOXALL  |       |
| DRAWN:    |      | M.PERREN  |       |

- NOTES:**
1. RECOMMENDED HOLE SIZE =  $\phi 1.10 \pm 0.05$ mm
  2. RECOMMENDED PIN DIAMETER =  $\phi 0.41$  TO  $0.51$ mm
  3. D01-97910XX SHOWN FOR ILLUSTRATION PURPOSES ONLY



**TOLERANCES**  
 X. =  $\pm 1$ mm  
 X.X =  $\pm 0.50$ mm  
 X.XX =  $\pm 0.20$ mm  
 X.XXX =  $\pm 0.01$ mm  
 ANGLES =  $\pm 5^\circ$   
 UNLESS STATED

THIS DRAWING AND ANY INFORMATION OR DESCRIPTIVE MATTER SET OUT HEREON ARE CONFIDENTIAL AND COPYRIGHT PROPERTY OF THE HARWIN GROUP AND MUST NOT BE DISCLOSED, LOANED, COPIED OR USED FOR MANUFACTURING, TENDERING OR FOR ANY OTHER PURPOSE WITHOUT THEIR WRITTEN PERMISSION.

**MATERIAL & FINISH:**  
 SEE ABOVE

**TITLE:**  
 H3192-XX SUB-MIN SOCKETS  
 ON CARRIER STRIP

**DRAWING NUMBER:**  
 D01-979XXXX

SHT  
 2  
 OF 2