

HARWIN

FLECTO

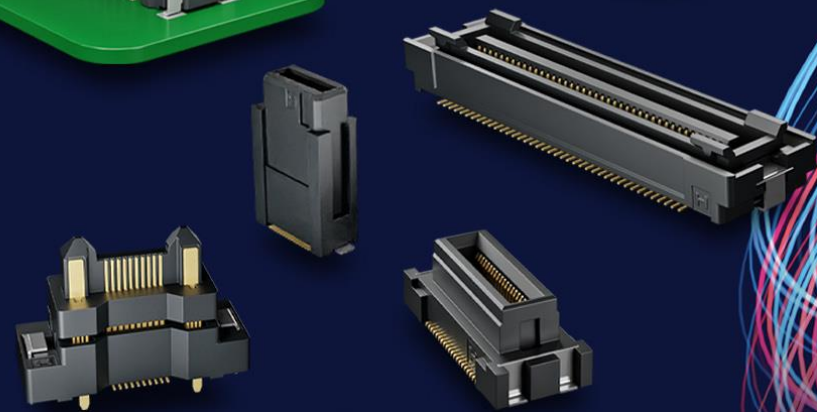

SMALLER CONNECTIONS FOR THE INDUSTRY

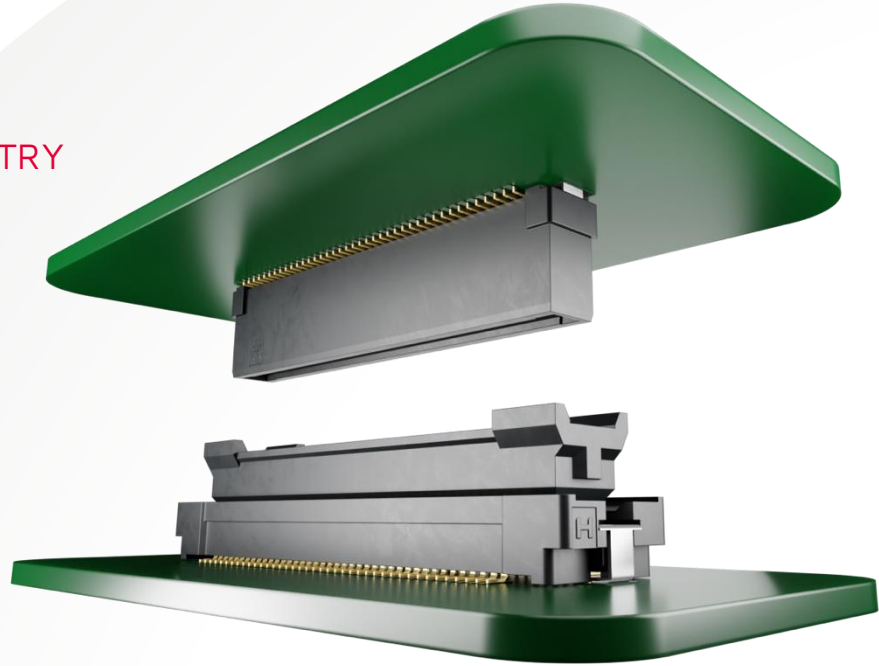

Industrial and automation systems require more features, but control modules must occupy less space. Hand-held products for both Consumer and Business must be compact but highly capable. These needs result in stacked boards with multiple micro-pitch connections.

[Flecto Floating Connectors](#) allow for multiple connectors between the same two PCBs, without the issue of placement accuracy.

FLOATING BOARD-TO-BOARD CONNECTIONS



When you have two connectors mating the same two PCBs, the tolerance of the product location (whether from PCB manufacture, paste location, pick and place accuracy or a combination of these) can mean that one or both connectors will encounter additional side-loading. This has the risk of long-term stress and damage on the connectors.

Flecto connectors eliminate this, with the male plug mating contact areas able to “float” within the housing.

FEATURES - TOLERANCE TO MISALIGNMENT

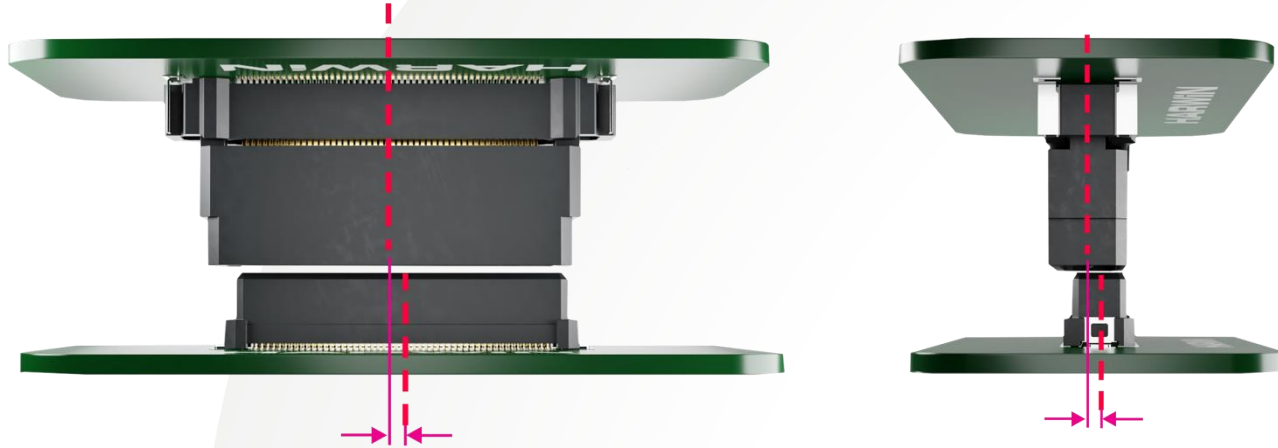

The connectors can be offset before mating by up to 0.5mm (up to 0.8mm for some ranges). This eliminates connection issues caused by placement tolerances and solder misalignment problems.

Any stresses are eased by the movement of the male plug connector, and the mating process during equipment assembly is easier and faster.

FEATURES - TOLERANCE TO MISALIGNMENT

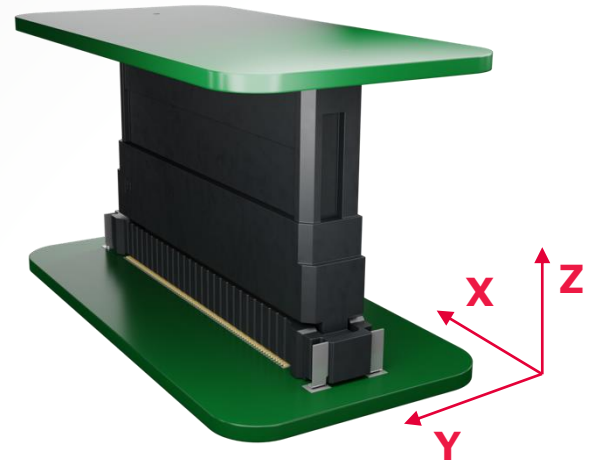
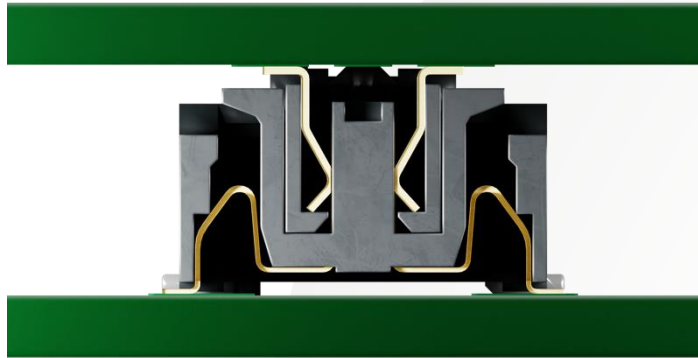

The connectors can also be offset when mated. The "floating" section in the male plug connector enables up to $\pm 0.5\text{mm}$ of movement in the X, Y and Z axes (up to $\pm 0.8\text{mm}$ in X and Y for some ranges). This allows for multiple connectors mating between two PCBs, as all placement tolerances and solder misalignment problems are absorbed within the floating movement.

FLECTO

FEATURES – UP TO 12Gbit/s DATA RATE

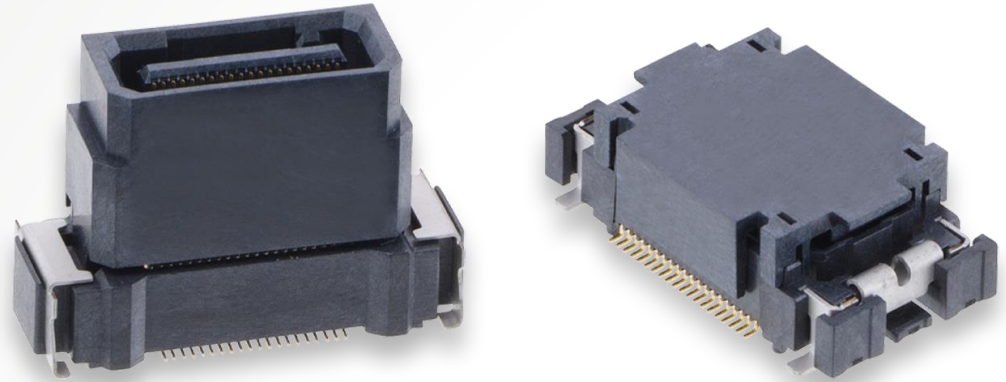

By using insertion loss and Near End Cross Talk (NEXT) testing methods, a conservative estimate of the data rate for mated connectors is established at:

- **4GHz, 8Gb/s** for 0.50mm (.0197") pitch
- **6GHz, 12Gb/s** for 0.635mm (.025") pitch
- **2.5GHz, 5Gb/s** for 0.8mm (.0315") pitch

Further information and test result graphs can be found in the [HT090 Test Report Summary](#).

FEATURES – SHROUDING AND POLARIZATION

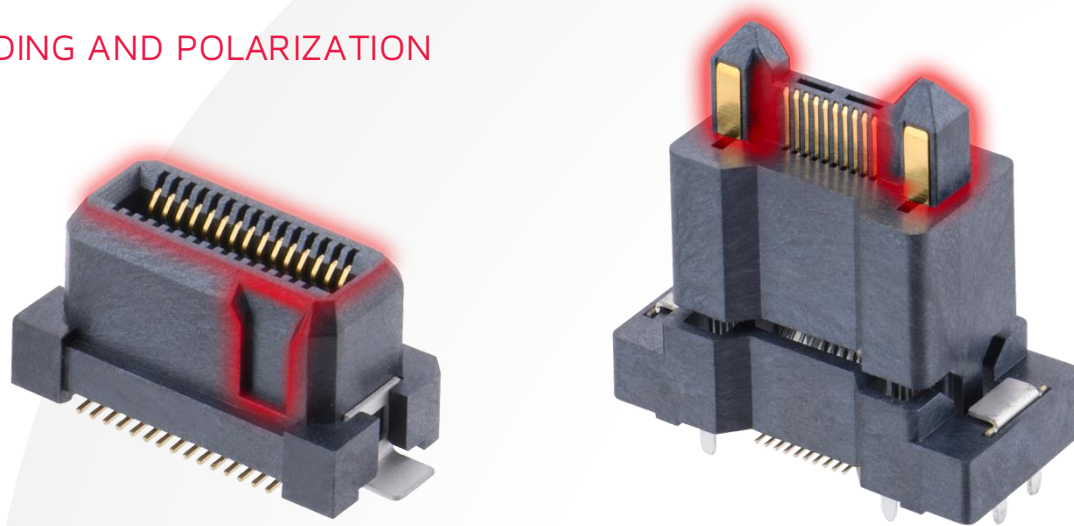

Some connectors in this range feature shrouded contacts, to prevent accidental damage to the miniature contacts. Some designs include polarization within the shroud to ensure assembly in only one direction. Check the individual product pages to confirm shrouding and polarization.

When power pins are included, they are located on large posts on the male plug side. This assists with blind mating, where visibility during the mating action is obscured or absent.

FEATURES – SURFACE MOUNT RETENTION TABS AND PEGS

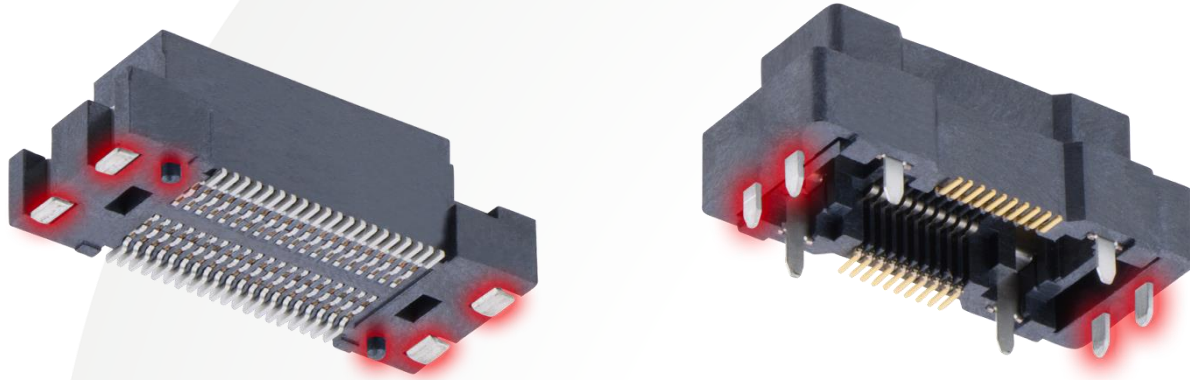

To assist with correct board placement, all signal-only connectors feature location pegs or posts to inhibit movement during the solder process. To improve surface mount retention to the PCB, retention tabs are located on either end of the connectors which provide additional solder strength.

Connectors including power pins have throughboard solderable posts for both location and additional solder strength.

FLECTO

READY FOR AUTO-PLACEMENT

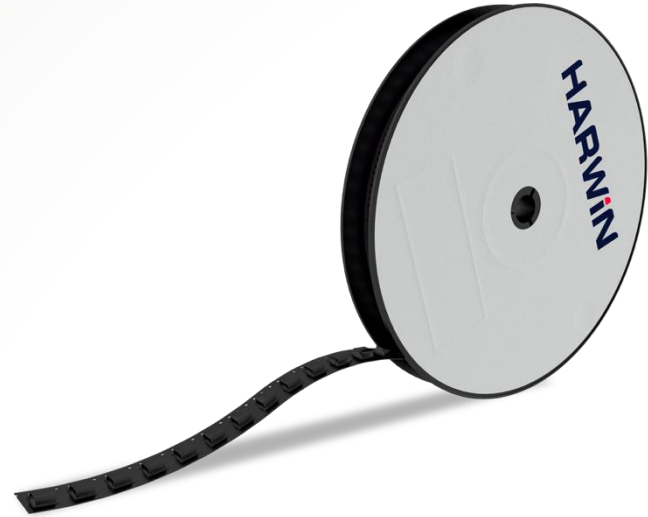
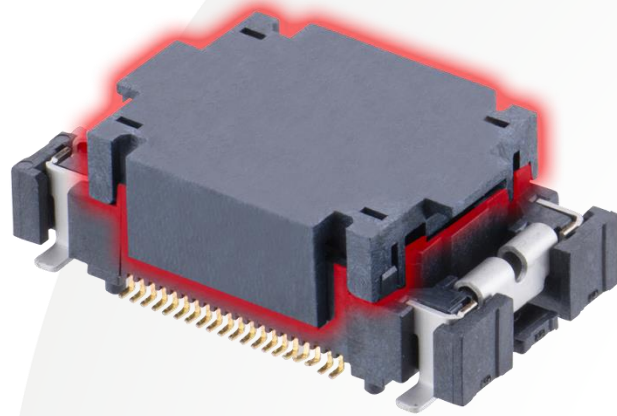

All Male Plug and Female connectors are available in Tape and Reel packaging options, ready to facilitate automated assembly processes to the PCB. All signal terminations are SMT, all power terminations are throughboard.

The straight connectors are fitted with disposable pick-and-place caps or tape – for the right-angle connectors, there is already a suitable flat surface on the connector itself.

FLECTO

FINE PITCH OPTIONS

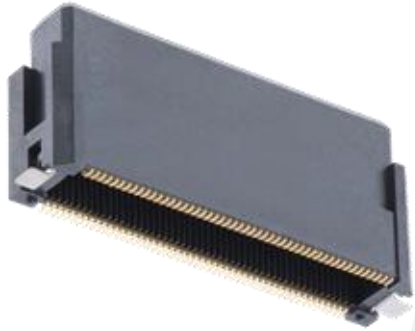

F10/F12: 0.50mm



F11: 0.5mm

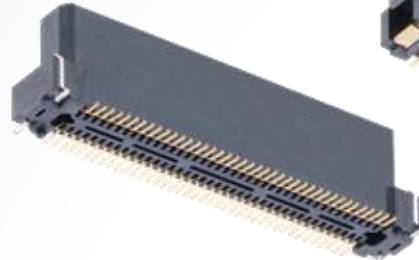

F20: 0.635mm

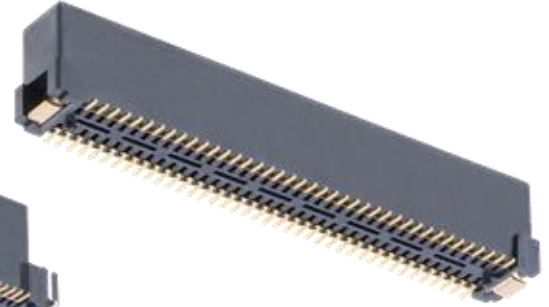

F30: 0.80mm

Flecto is available in 3 different pitches, with the smallest pitch also available with power pins:

- **F10 and F12 series** = 0.50mm (.0197") pitch - all signal, F10 does not mate with F12
- **F11 series** = 0.5mm (.0197") pitch - signal + power
- **F20 series** = 0.635mm (.025") pitch
- **F30 series** = 0.80mm (.0315") pitch

FLECTO

F10 SERIES – 0.5mm PITCH: VARIABLE HEIGHTS, ALL SIGNAL

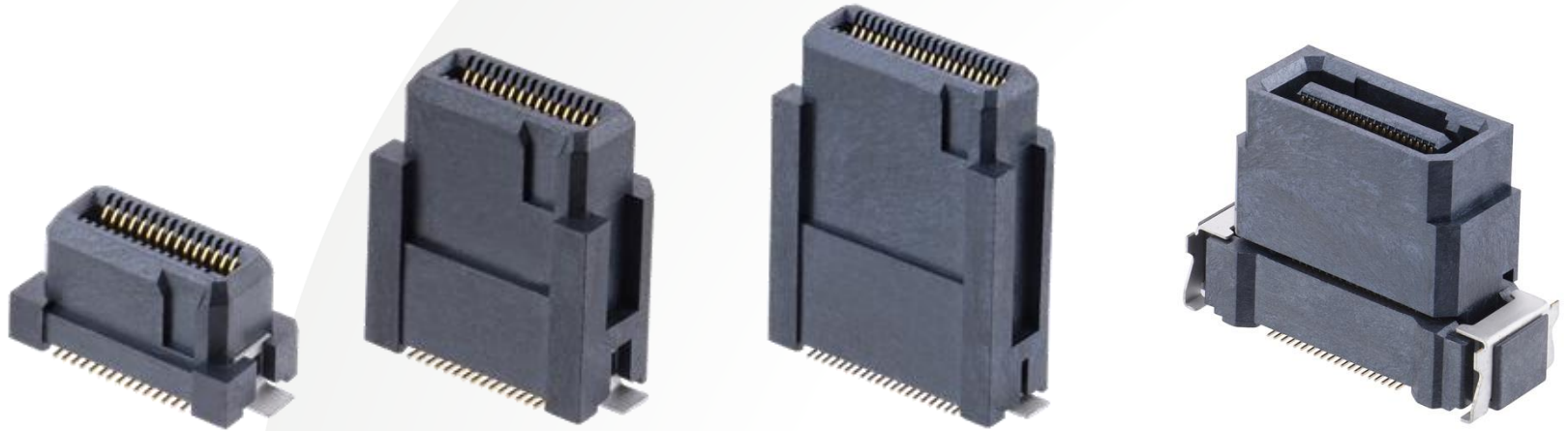

The F10 range has 3 different heights in the female receptacle connector, and the male plug connector incorporates the floating mechanism.

- **F10-100xx45R** = Female Receptacle SMT 6.40mm – mating height is 17.90mm nominal – 30 and 100 contact options
- **F10-101xx45R** = Female Receptacle SMT 13.40mm – mating height is 24.90mm nominal – 30 and 100 contact options
- **F10-102xx45R** = Female Receptacle SMT 18.40mm – mating height is 29.90mm nominal – 30 / 40 / 60 / 80 / 100 / 120 / 140 / 160 contact options
- **F10-200xx45R** = Male Plug SMT – mating height is dependent on female receptacle connector – 30 / 40 / 60 / 80 / 100 / 120 / 140 / 160 contact options

F11 SERIES – 0.5mm PITCH: VARIABLE HEIGHTS, SIGNAL + POWER

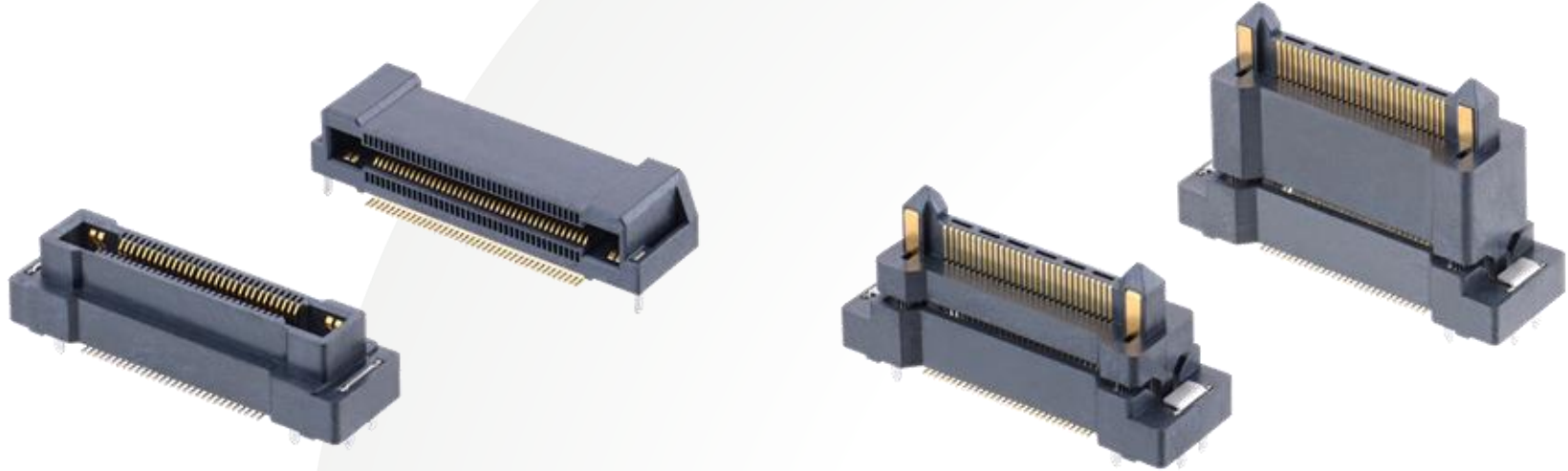

Female Receptacle connectors are supplied in straight or right-angle format. The 4 power contacts are located around the 2 mating posts on the male plug connector, internal contacts on the female receptacle. The male plug connectors have 2 different heights and incorporate the floating mechanism. Signal contact counts options are 20 / 40 / 60 / 80 / 100 / 120.

Female Receptacle connectors:

- **F11-100xxx42R** = Straight
- **F11-111xxx42R** = Right-angle (90°)

Male Plug connectors:

- **F11-200xxx42R** = 13.20mm high, 15.00mm nominal mating height with F11-100
- **F11-201xxx42R** = 18.20mm high, 20.00mm nominal mating height with F11-100

F12 SERIES – 0.5mm PITCH: COMPACT MATING HEIGHT

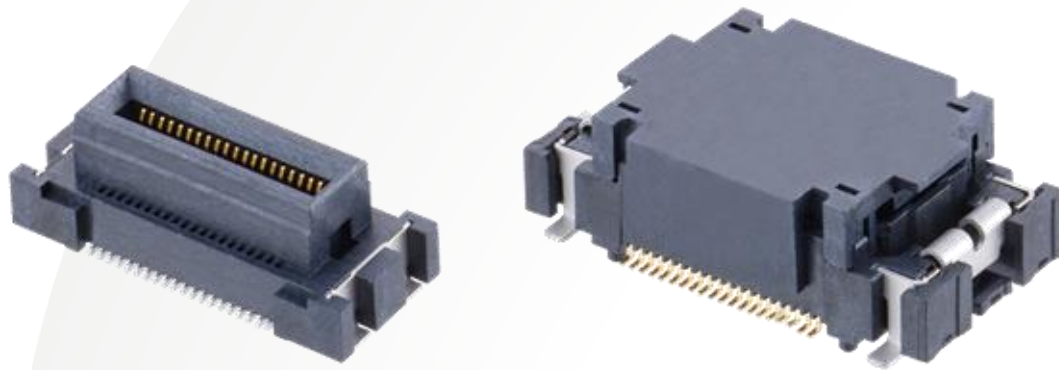

The F12 mating connectors are suitable for a smaller board-to-board height requirement with a nominal mated height of 7.65mm. Available with 40 contacts.

- **F12-10004042R** = Female Receptacle SMT
- **F12-20004045R** = Male Plug SMT

F20 SERIES – 0.635mm PITCH: VARIABLE HEIGHTS, ALL SIGNAL

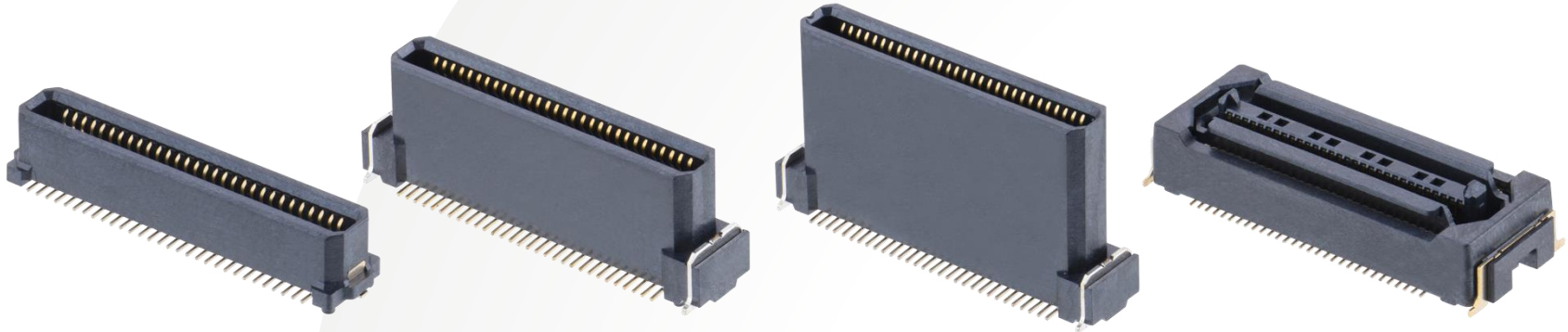

The F20 range also has 3 different heights in the female receptacle connector, and the male plug connector incorporates the floating mechanism. 60 and 80 pin counts are available.

- **F20-100xx45R** = Female Receptacle SMT 4.28mm – mating height is 5.98mm nominal
- **F20-101xx45R** = Female Receptacle SMT 8.18mm – mating height is 9.88mm nominal
- **F20-102xx45R** = Female Receptacle SMT 13.18mm – mating height is 14.88mm nominal
- **F20-200xx45R** = Male Plug SMT – mating height is dependent on female receptacle connector

F30 SERIES – 0.8mm PITCH: VARIABLE HEIGHTS, ALL SIGNAL



Nominal mating heights		MALE PLUG	
		F30-200	F30-201
FEMALE RECEPTACLE	F30-100	8.00mm	11.75mm
	F30-101	9.00mm	12.75mm
	F30-102	20.95mm	24.70mm



The F30 range has 3 different heights in the female receptacle connector, and 2 different heights in the male plug connector, which also incorporates the floating mechanism.

Female Receptacle connectors:

- **F30-100xx45R** = 6.80mm high, 60 or 80 contacts
- **F30-101xx45R** = 7.80mm high, 60 or 80 contacts
- **F30-102xx45R** = 19.75mm high, 60 / 80 / 100 contacts

Male Plug connectors:

- **F30-200xx45R** = 4.70mm high, 60 / 80 / 100 contacts
- **F30-201xx45R** = 8.45mm high, 60 or 80 contacts

ELECTRICAL SPECIFICATIONS

Current Rating	Signal Contacts = 0.5A per contact (0.4A for F10 series) Power Contacts = 3A per contact
Contact Resistance	100m Ω max
Insulation Resistance	100M Ω min

View the [C057XX Component Specification](#) for more detail.

MECHANICAL & ENVIRONMENTAL SPECIFICATIONS

X, Y and Z Axis movement / misalignment	Z axis = ±0.5mm (all ranges) X / Y axes for F10, F12, F30-200 = ±0.5mm X / Y axes for F20 = ±0.7mm X / Y axes for F30-201 = ±0.8mm
Temperature Range	Signal + Power (F11 series) = -55°C to +105°C Signal Only = -40°C to +105°C
Durability	100 mating cycle operations min (F10, F11, F20, F30) 30 mating cycle operations min (F12)

The complete product range is manufactured using LCP housings and copper alloy contacts.

Maximum recommended solder temperature (soldering heat resistance) is 260°C for 10 seconds.

LEGISLATION – ENVIRONMENTALLY FRIENDLY MATERIAL



The materials used in the Flecto connectors do not contain any Lead, Brominated Flame Retardants, Red Phosphor (PFOS/PFOA) or Antimony; they are Halogen-free. They are fully RoHS Compatible and contain no REACH SVHCs.

MARKETS

Electric Vehicles

- Infotainment systems
- Inverter units
- Battery Management Systems
- LIDAR

Smart Factory

- Factory Automation
- Drives & Controls
- Robotics
- Sensor Units
- Vision Systems

Embedded Systems

- Datacoms
- Home automation
- Medical Devices
- Transit systems

LEARN MORE ABOUT OUR OTHER RANGES



HIGH RELIABILITY
WITH SUPREME
PERFORMANCE



DEPENDABLE
CONNECTIVITY
ACROSS THE BOARD



INNOVATIVE
DESIGNS FOR
EASY ASSEMBLY

Find out more about our full range
of inter-connection solutions at
www.harwin.com

HRI
RANGE

BBi
RANGE

EZi
RANGE

GET HELP FROM A HARWIN EXPERT

Our experts are specialists in their field with many years of experience in their respective roles and industries.

Find an expert that can help you with your enquiry.

[Click Here >>](#)

CAD Models and Evaluation Samples also available at www.harwin.com





HARWIN

CONNECT TECHNOLOGY
WITH CONFIDENCE



E: support@harwin.com

[WWW.HARWIN.COM](http://www.harwin.com)