

Customer Information Sheet

Specifications

Material:
Contact = Brass

Finish:
05 = Gold over nickel

Packing:
Bulk

For complete specification, see component specification C005XX (latest issue)

Order Code:	M80-04000XX
Finish:	05- Gold

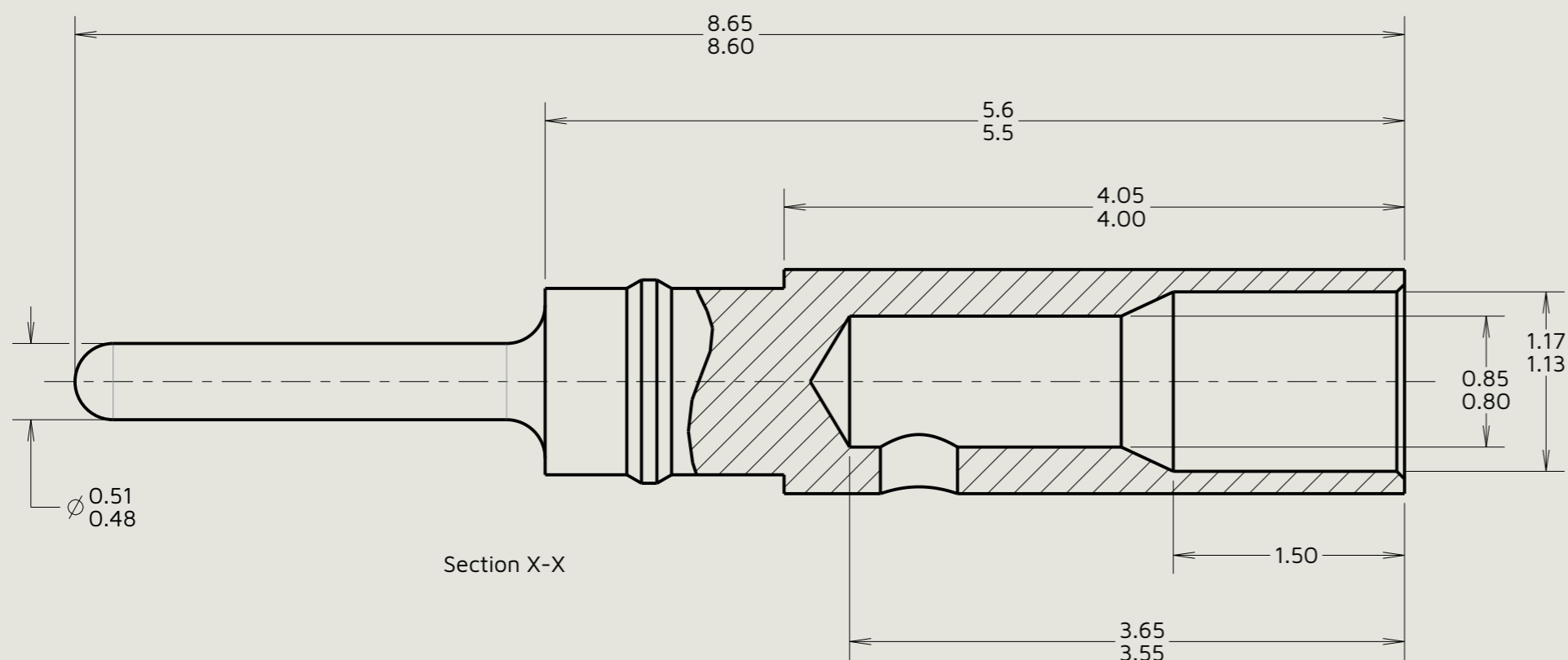

Section X-X

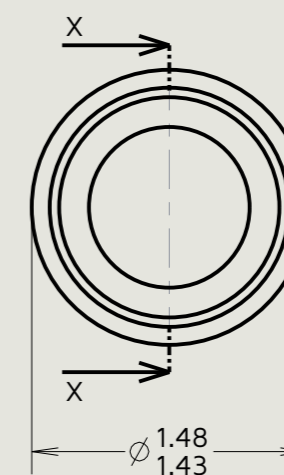

Scale 10:1

AY	19	20.03.26	38257
Initials	Rev.	Date	CO
JMB	10	07.08.06	9370

- Notes:**
- Suitable for wire gauge 22 AWG. Maximum insulation diameter Ø1.10mm. BS 3G 210 Type A and wire types listed on Component Specification C049XX (latest issue) are recommended. Strip wire by 2.00mm for crimping.
 - Recommended crimp tooling = M22520/2-01 with positioner T5747.
 - For crimping method, see Instruction Sheet IS-01.

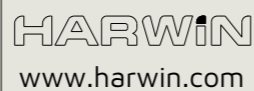

This drawing and any information or descriptive matter set out hereon are confidential and copyright property of the Harwin group and must not be disclosed, loaned, copied or used for manufacturing, tendering or for any other purpose without their written permission.

TOLERANCES
 X. = ±0.50mm
 X.X = ±0.30mm
 X.XX = ±0.10mm
 X.XXX = ±0.01mm
 Angles = ±5°
 Unless stated

Third angle projection

 Sheet scale: 25:1
 Do not scale
 Sheet size: A3

MATERIAL:
See Specification
FINISH:
See Specification

Title:
Datamate L-Tek Male Crimp Plug Contact (22 AWG)
Drawing number:
M80-04000XX
 SHT 2 OF 2