

Customer Information Sheet

Specifications:

- Material:**
 Shell = Aluminium alloy
 Insulator = Synthetic rubber
 Grommet = Synthetic rubber
 Contact = Copper alloy
Finish:
 Shell = Zinc Cobalt alloy, black
 Contact = Silver

For mechanical/electrical requirements, see component specification CO45XX (latest issue)

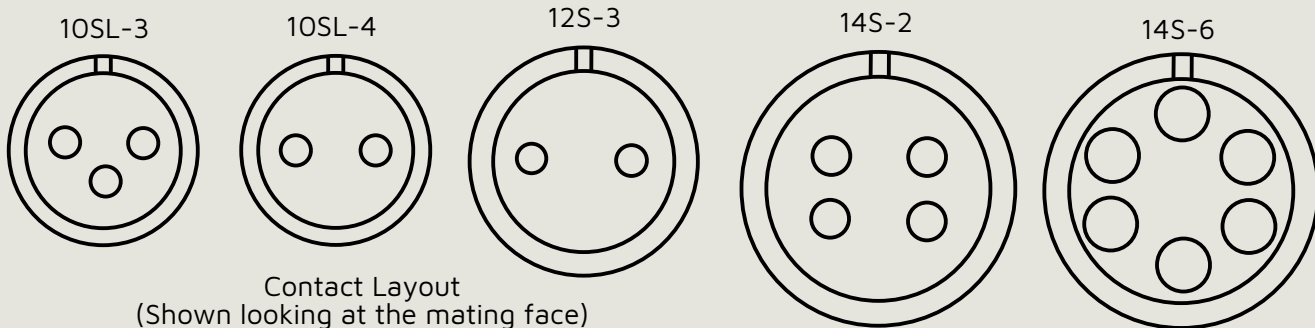

Contact Layout
(Shown looking at the mating face)

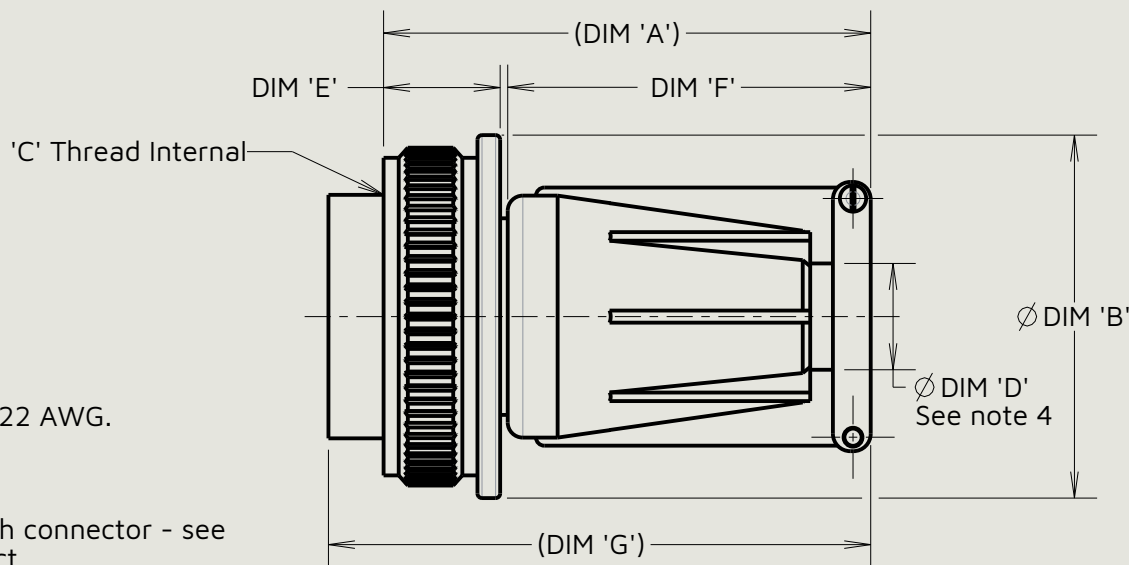

Notes:

- Product is RoHS compliant.
- Product is packed in bags.
- Recommended wire size 16-22 AWG.
- Cable clearance.
- Recommended wire strip Length = 7.5mm.
- Rubber bushing supplied with connector - see Table 1 for applicable product

Order Code: C90-3106FXXXX-XX

Shell Size (Contact Layout):
 10SL-3, 10SL-4, 12S-3, 14S-2
 14S-6

Contact Gender:
 P - Male
 S - Female

Table 1: Dimension Variants

| Shell Size | (DIM 'A') | ØDIM 'B' | 'C' THREAD | ØDIM 'D' | DIM 'E' | DIM 'F' | (DIM 'G') | Rubber Bushing |
|------------|-----------|------------|------------|------------|------------|------------|-----------|----------------|
| 10SL | 48.50 | 22.23±0.39 | 5/8-24UNEF | 7.90±0.12 | 12.29 | 33.67±0.57 | 53.05 | C90-3240-4 |
| 12S | 49.60 | 25.40 | 3/4-20UNEF | 7.90±0.12 | 12.10 | 33.40±0.12 | 53.80 | C90-3240-4 |
| 14S | 52.77 | 28.30 | 7/8-20UNEF | 11.18±0.13 | 12.10±0.10 | 35.05±0.13 | 55.55 | C90-3240-6 |

| | | | |
|----------|------|----------|-------|
| JW | 12 | 05.12.25 | 37173 |
| Initials | Rev. | Date | CO |
| RA | 4 | 01.09.10 | 10909 |



This drawing and any information or descriptive matter set out hereon are confidential and copyright property of the harwin group and must not be disclosed, loaned, copied or used for manufacturing, tendering or for any other purpose without their written permission.

TOLERANCES
 X. = ±0.50mm
 X.X = ±0.30mm
 X.XX = ±0.10mm
 X.XXX = ±0.01mm
 Angles = ±5°
 Unless stated

Third angle projection

 Sheet scale: 2:1
 Do not scale
 Sheet size: A4

MATERIAL:
 See above
FINISH:
 See above

Title:
 Straight Plug
Drawing number:
 C90-3106FXXSX-XX
 SHT 2 OF 2