

HARWIN

Instruction Sheet

IS-37

Gecko Hand Crimp Tool Z125-900

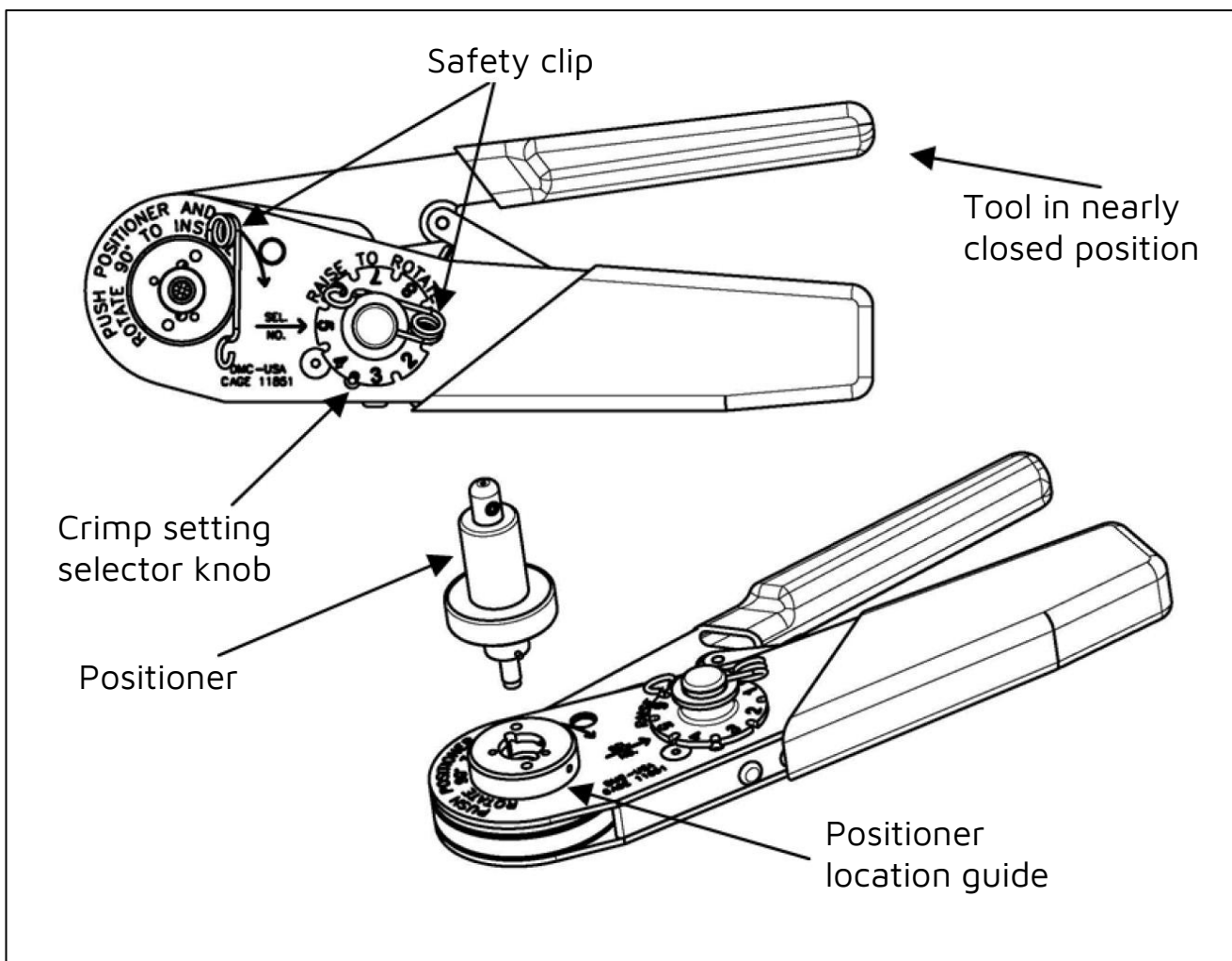

CRIMP CONTACT INFORMATION

This Hand Crimp Tool has been designed for use with the following Gecko Crimp Contacts (when used with Positioner Z125-901):

- G125-0010005..... Female Receptacle crimp contact for 26 AWG wire
- G125-0020005 Female Receptacle crimp contact for 28-32 AWG wire
- G125-1010005 Male Plug crimp contact for 26 AWG wire
- G125-1020005..... Male Plug crimp contact for 28-32 AWG wire

GENERAL INFORMATION

The hand crimp tool Z125-900 consists of a basic hand tool, which should be used with a positioner.

The contact is correctly crimped when the tool is free to open at the fully closed position, i.e., when the ratchet releases. The tool cannot be opened without completing the cycle.

TOOL PREPARATION

1. Check that the tool is in the open position. Remove the safety clip from the positioner locator (do not discard).
2. Insert the Positioner into the positioner locator and turn it 90° in the direction shown on the tool, until the bayonet pins lock.
3. Install the safety clip back into the positioner locator (optional).
4. Check Table 1 for the correct crimp tool setting of the wire size you wish to crimp.
5. Remove the safety clip from the selector knob (do not discard).
6. Lift and turn the selector knob until the correct crimp tool setting is lined up with the "Sel. No." arrow. Lower the selector knob, ensuring the locating peg lines up with a notch.
7. Install the safety clip back into the selector knob.

CRIMPING PROCEDURE

See also the Gecko crimping instruction video at <https://www.youtube.com/HarwinGroup> for visual guidance.

1. Ensure that the wire to be crimped is within the specified range of sizes for the contact and the crimp tool. Failure to use the specified wire size will result in poor quality crimps and possible tool damage.

Contact	Wire Gauge (AWG)	Stranding (mm)	Crimp Tool Setting	Minimum pull-off force (N)
G125-00100XX G125-10100XX	26	7/0.15	6	18
G125-00200XX G125-10200XX	28	7/0.13	5	12.5
	30	7/0.10	5	7
	32	7/0.08	5	4

Table 1 - Crimp Tool Settings and Forces

- Cut the end of the cable to be terminated so that there is a clean cut end (Figure A). Strip the cable to the correct length (Figure B). We recommend that when the wire is stripped, it is clamped or supported close to the stripping area - this will prevent insulation slippage. Suitable wire strippers (such as a PTFE wire stripper) must be used. This should result in all the strands lying together neatly. If the lay of the strands is disturbed, it may be re-imposed with a slight twist. Ensure no strands are damaged or missing.

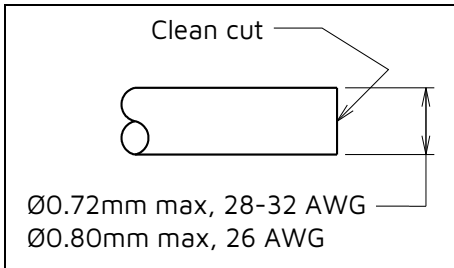

Figure A - Clean cut end

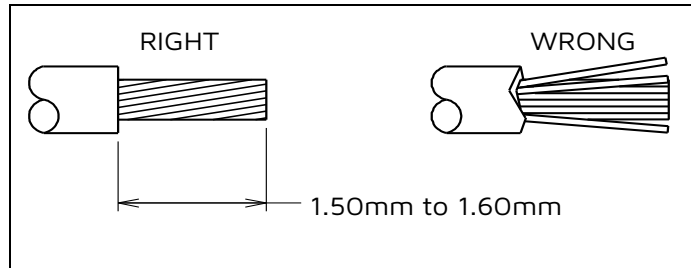

Figure B - Strip wire

Caution: Wear Nitrile/Latex powder free gloves or Finger cots when handling contacts to prevent hands from contaminating contacts.

- Load the terminated end of the cable into the crimp barrel of the socket. Ensure the wire is fully inserted, with all strands in place (Figure C).

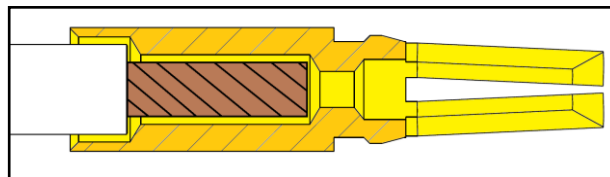

Figure C - All strands in inner crimp bore

Note: If there is a cross hole on the crimp barrel, this is not an inspection hole (it is designed to assist with plating processes). However, it may give approximate guidance to the location of the conductor. After crimping the contact, the crimp indents may overlap this hole.

- Apply pressure to the positioner plunger in the direction shown by the arrow (Figure D and E). Release the plunger, to ensure it is moving freely and returns to the default position without jamming. Once satisfied with plunger operation, re-apply pressure in direction shown by the arrow (Figure D and E).
- Maintain pressure on the plunger, and insert the crimp contact with cable fully into the positioner (Figure F).

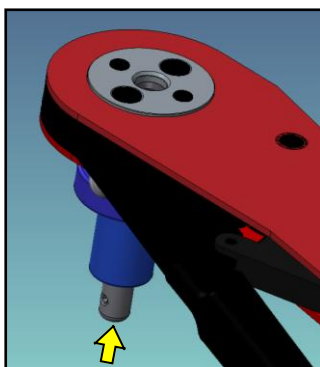

Figure D

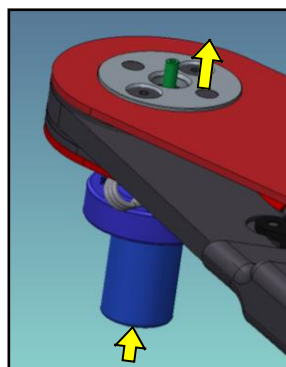

Figure E

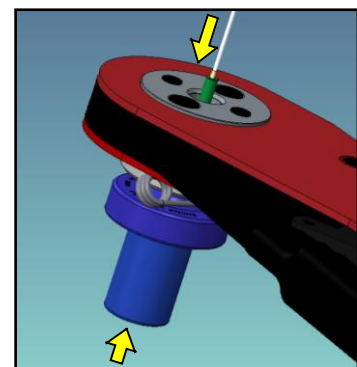

Figure F

6. Apply light pressure to the wire in the direction shown by arrow in Figure G. Slowly release pressure on the plunger, and allow it to return to its default position as shown.

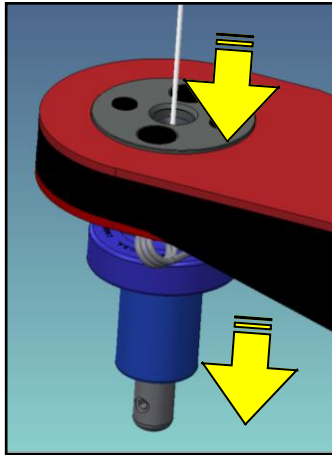

Figure G

7. **Caution: Failure to allow the positioner plunger to return to its default position may result in damage to the crimp tool indenter jaws during crimping.**

If the plunger is not fully returned, the indenters could crimp on the plunger, damaging both the Z125-900 hand tool and the Z125-901 positioner (Figure H).

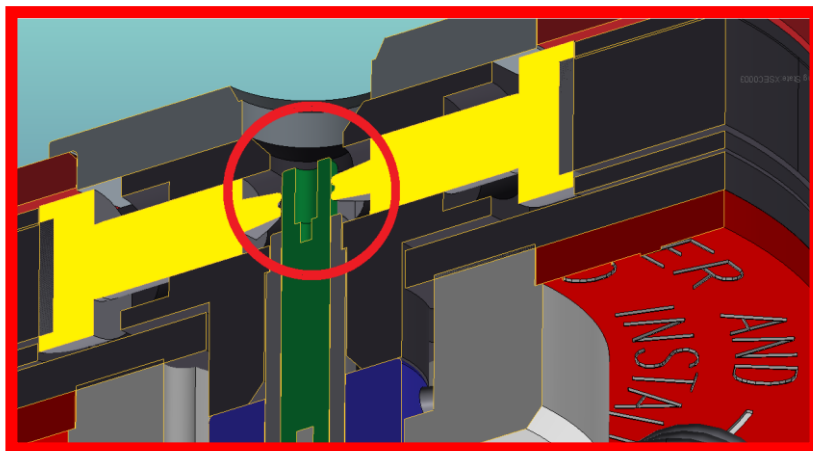

Figure H – Damage risk if the positioner is not fully back to default position

8. Squeeze the handles of the crimp tool fully together, until the ratchet releases. The handle will return to the open position. Remove the crimped contact and wire.
9. Crimp joints should be checked for:
- Correct combination of cable, tool setting and crimp termination.
 - Correct form of indents and location of crimp.
 - Freedom of fracture, rough edges and flash.
 - Adequate insertion of all conductor strands in the crimp barrel.
 - Absence of damage to the conductor or the insulation.



CONTACT ASSEMBLY TO HOUSING PROCEDURE

Contacts are assembled to housings using the Assembly Tool Z125-902. See Instruction Sheet IS-38 for details on assembly.

CARE OF TOOL

There is virtually no maintenance required for the Z125-900 tool. However, it is good practice to keep the indenter tips free of debris. A small wire brush may be used for this purpose.

We strongly recommend that you:

1. **DO NOT** immerse tools in any cleaning solution.
2. **DO NOT** spray oil into tool to lubricate.
3. **DO NOT** attempt to disassemble tool or make repairs.

This is a precision crimp tool and should be handled as such.

