

# Customer Information Sheet

IF IN DOUBT - ASK

©

NOT TO SCALE

THIRD ANGLE PROJECTION

ALL DIMENSIONS IN mm

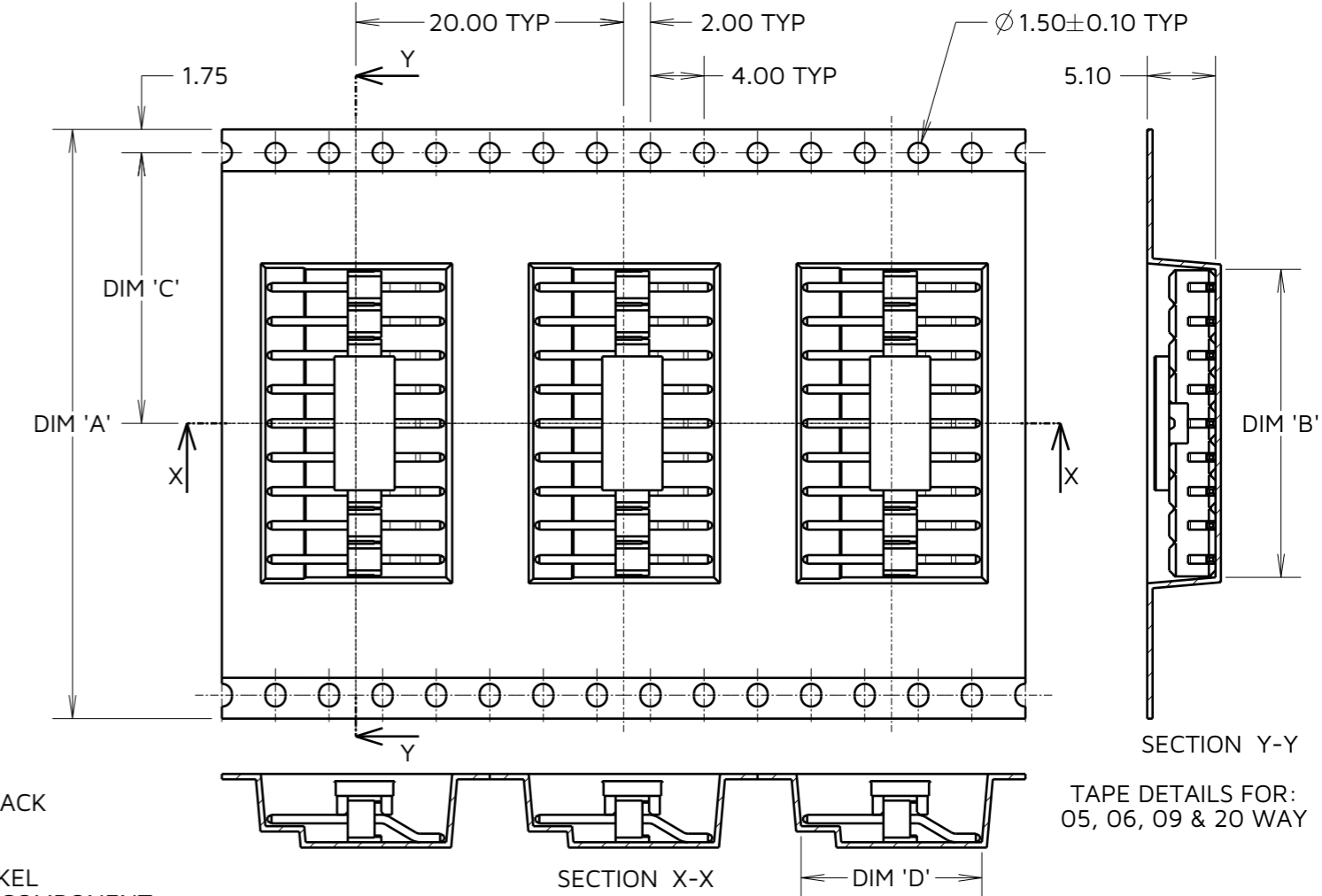
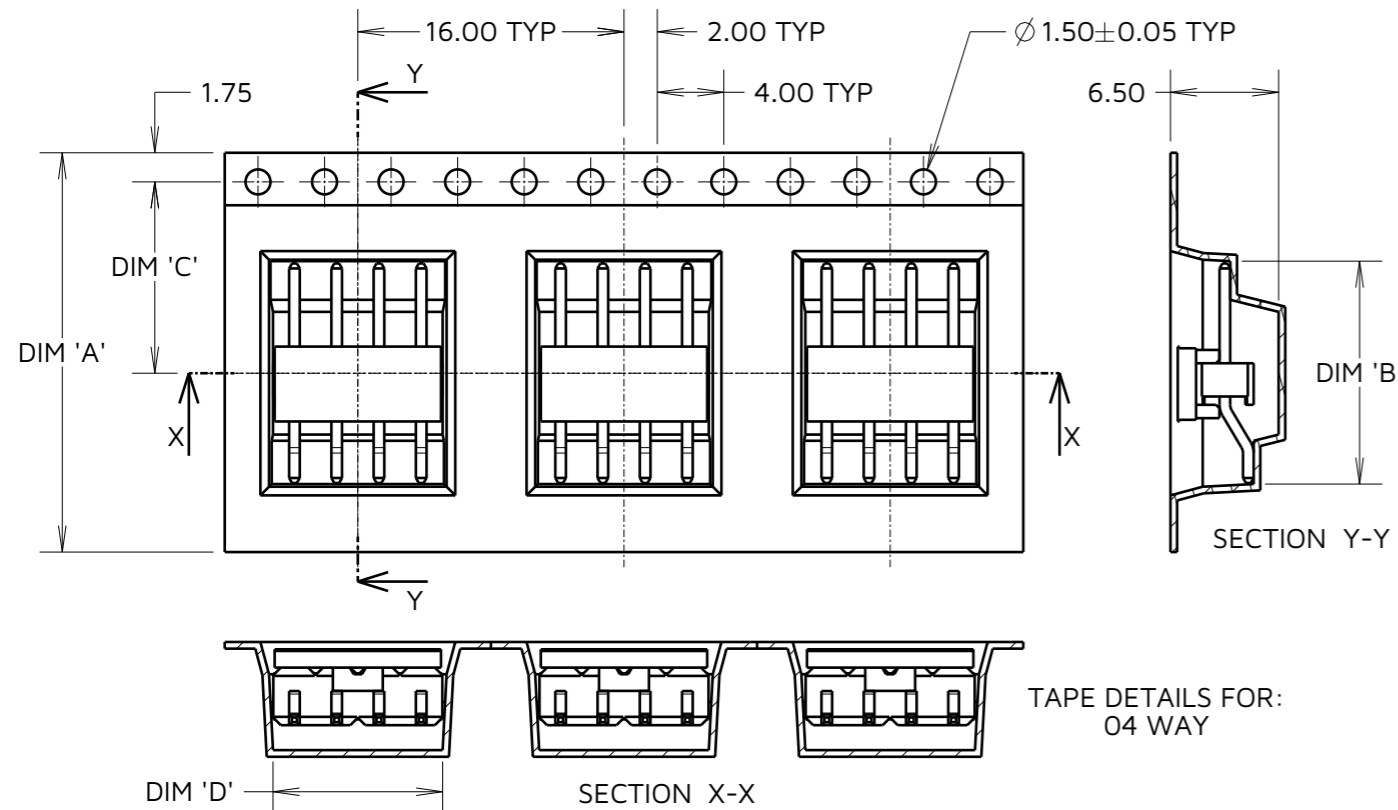

**SPECIFICATION:**  
**MATERIAL:**  
 HOUSING = NYLON 6T UL94V-0, BLACK  
 CONTACT = BRASS  
**FINISH:**  
 CONTACT = GOLD FLASH OVER NICKEL  
 FOR COMPLETE SPECIFICATION, SEE COMPONENT SPECIFICATION C001XX (LATEST ISSUE).

**NOTE:**  
 1. THIS PRODUCT IS TAPE AND REELED IN GENERAL ACCORDANCE WITH EIA-481 (ELECTRONIC INDUSTRIES ASSOCIATION).  
 2. PART NUMBER M20-8900905 SHOWN FOR ILLUSTRATIVE PURPOSES ONLY. SEE ORDER CODE.

TABLE 1: DIMENSIONS

PART No.	DIM 'A'	DIM 'B'	DIM 'C'	DIM 'D'	QUANTITY PER REEL
M20-8900305R	24.0 ± 0.3	13.74 ± 0.10	11.50	8.02 ± 0.10	500
M20-8900405R		13.40 ± 0.30		10.20 ± 0.30	
M20-8900505R		13.15 ± 0.20		13.90 ± 0.20	600
M20-8900605R	32.0 ± 0.3	15.54 ± 0.30	14.20	13.50 ± 0.30	500
M20-8900905R	44.0 ± 0.3	23.00 ± 0.30	20.20	13.50 ± 0.30	500
M20-8902005R	72.0 ± 0.3	51.20 ± 0.30	34.20	13.80 ± 0.30	600

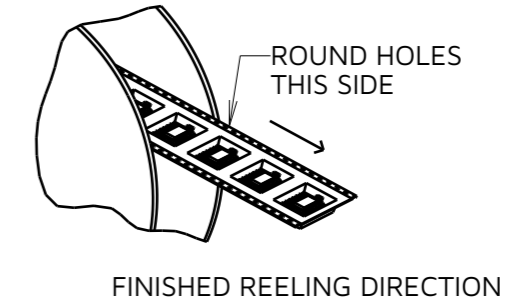
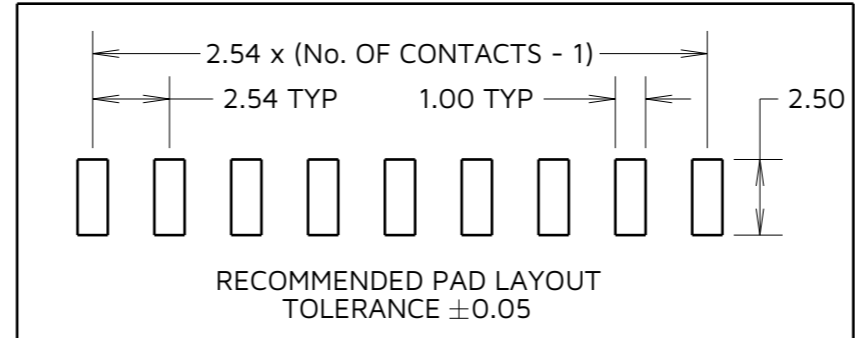
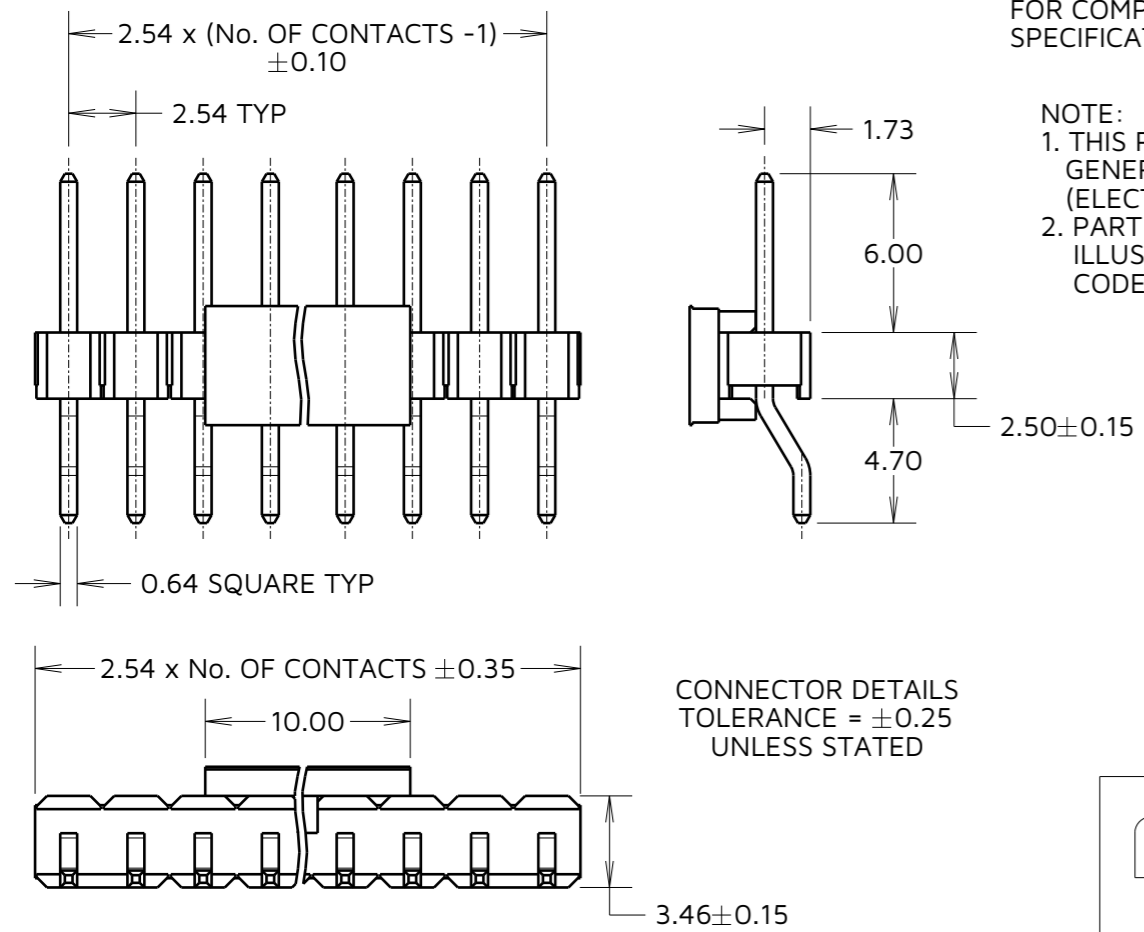

RTP	6	07.10.24	34869
NAME	ISS.	DATE	CN/CO
APPROVED:		R.PORTLOCK	
CHECKED:		A.YEOMANS	
DRAWN:		S.BENNETT	
ASSEMBLY DRG:			

**HARWIN**  
[www.harwin.com](http://www.harwin.com)

**TOLERANCES**  
 X. = ±1mm  
 X.X = ±0.50mm  
 X.XX = ±0.20mm  
 X.XXX = ±0.01mm  
 ANGLES = ±5°  
 UNLESS STATED

THIS DRAWING AND ANY INFORMATION OR DESCRIPTIVE MATTER SET OUT HEREON ARE CONFIDENTIAL AND COPYRIGHT PROPERTY OF THE HARWIN GROUP AND MUST NOT BE DISCLOSED, LOANED, COPIED OR USED FOR MANUFACTURING, TENDERING OR FOR ANY OTHER PURPOSE WITHOUT THEIR WRITTEN PERMISSION.

**MATERIAL:**  
 SEE ABOVE

**TITLE:**  
 SIL HORIZONTAL SMT HEADER IN TAPE AND REEL  
**DRAWING NUMBER:**  
 M20-890XX05R  
 SHT 2 OF 2