

Customer Information Sheet

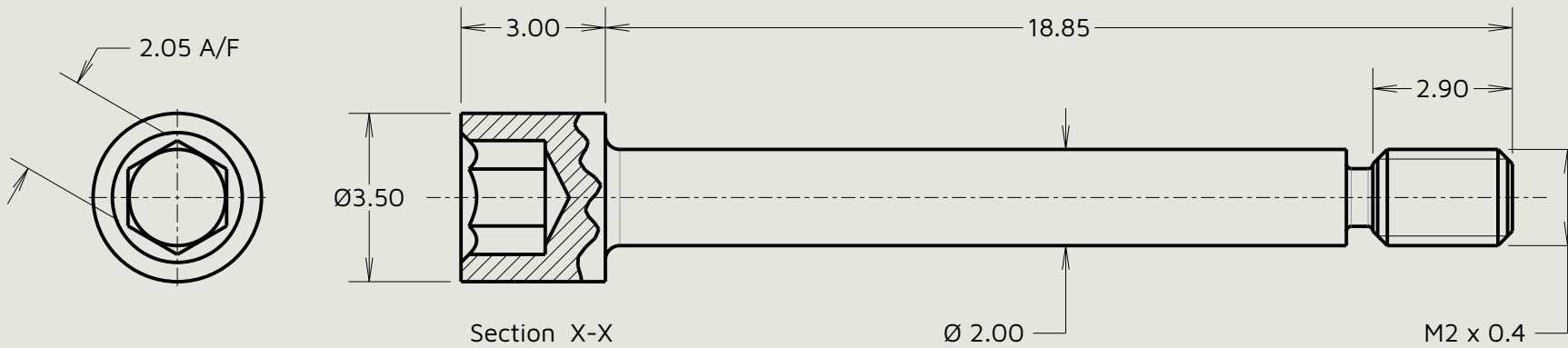
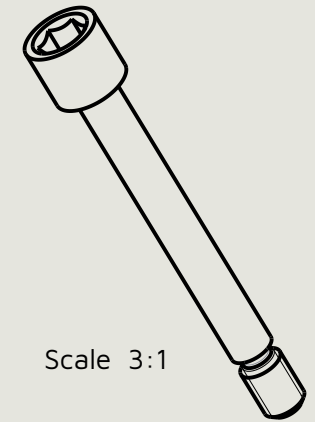

Notes:
1. Designed to be used for the M80-946XX02 Datamate backshell kit.

JW	2	23.03.26	38088
Initials	Rev.	Date	CO
MSP	1	06.01.17	-----

HARWIN
www.harwin.com

This drawing and any information or descriptive matter set out hereon are confidential and copyright property of the Harwin group and must not be disclosed, loaned, copied or used for manufacturing, tendering or for any other purpose without their written permission.

TOLERANCES
X. = ±0.50mm
X.X = ±0.30mm
X.XX = ±0.10mm
X.XXX = ±0.01mm
Angles = ±5°
Unless stated

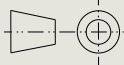
Third angle projection

Sheet scale: 7:1
Do not scale
Sheet size: A4

MATERIAL:
Stainless Steel
1.4305 To BS En
10088
FINISH:
Clean

Title:
Datamate Backshell Female Slotted Jackscrew
Drawing number:
M80-218A400

SHT
2
OF
2