

Customer Information Sheet

Specification:
 Material:
 Contact = Brass
 Finish:
 05- Gold over nickel
 Packing:
 Bulk
 For complete specification, see component specification C005XX (latest issue).

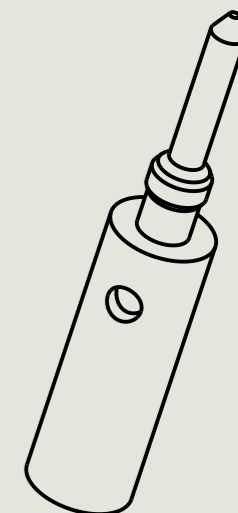

Scale 10:1

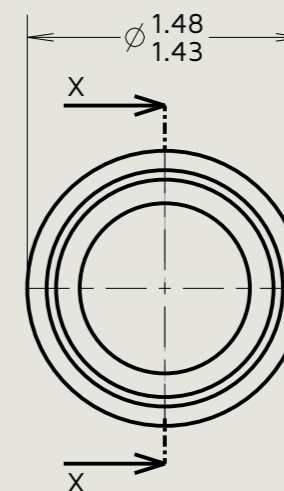
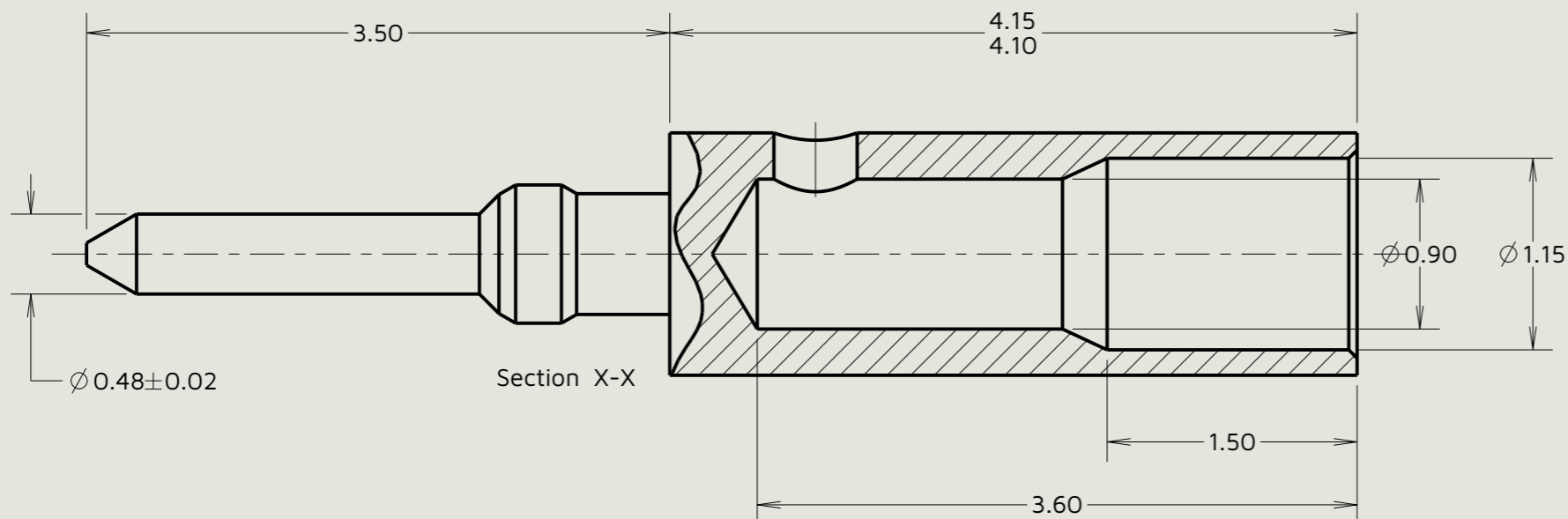

Order Code:
M80-19400XX
 Finish: _____
 05- Gold over nickel

ES	9	20.03.26	38257
Initials	Rev.	Date	CO
RA	1	26.11.08	10214

- Notes:
- Suitable for wire gauge 22 AWG. Maximum insulation diameter Ø1.10mm. BS 3G 210 Type A and wire type listed on Component Specification C049XX (latest issue) are recommended. Strip wire by 2.00mm for crimping.
 - Recommended crimp tooling = M22520/2-01 with positioner Z80-193.
 - For crimping method, see Instruction Sheet IS-01.

 www.harwin.com	This drawing and any information or descriptive matter set out hereon are confidential and copyright property of the Harwin group and must not be disclosed, loaned, copied or used for manufacturing, tendering or for any other purpose without their written permission.	TOLERANCES X. = ±0.50mm X.X = ±0.30mm X.XX = ±0.10mm X.XXX = ±0.01mm Angles = ±5° Unless stated	Third angle projection 	MATERIAL: See Specification	Title: Datamate Jackscrew Male Crimp Contact (22AWG)
		Sheet scale: 25:1 Do not scale Sheet size: A3	FINISH: See Specification	Drawing number: M80-19400XX	SHT 2 OF 2