

Customer Information Sheet

Specification:

Material:
Beryllium Copper

Finish:
05- Gold over Nickel

Packing:
Bag

For complete specification, see component specification C005XX (Latest Issue)

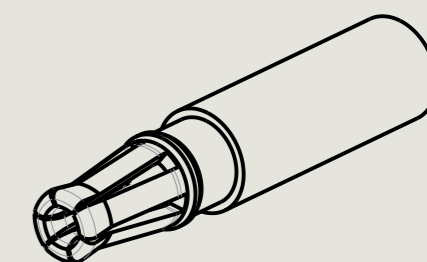
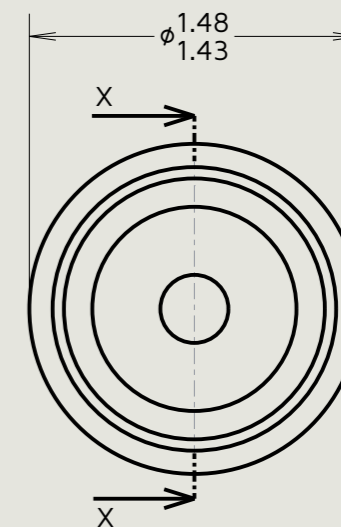
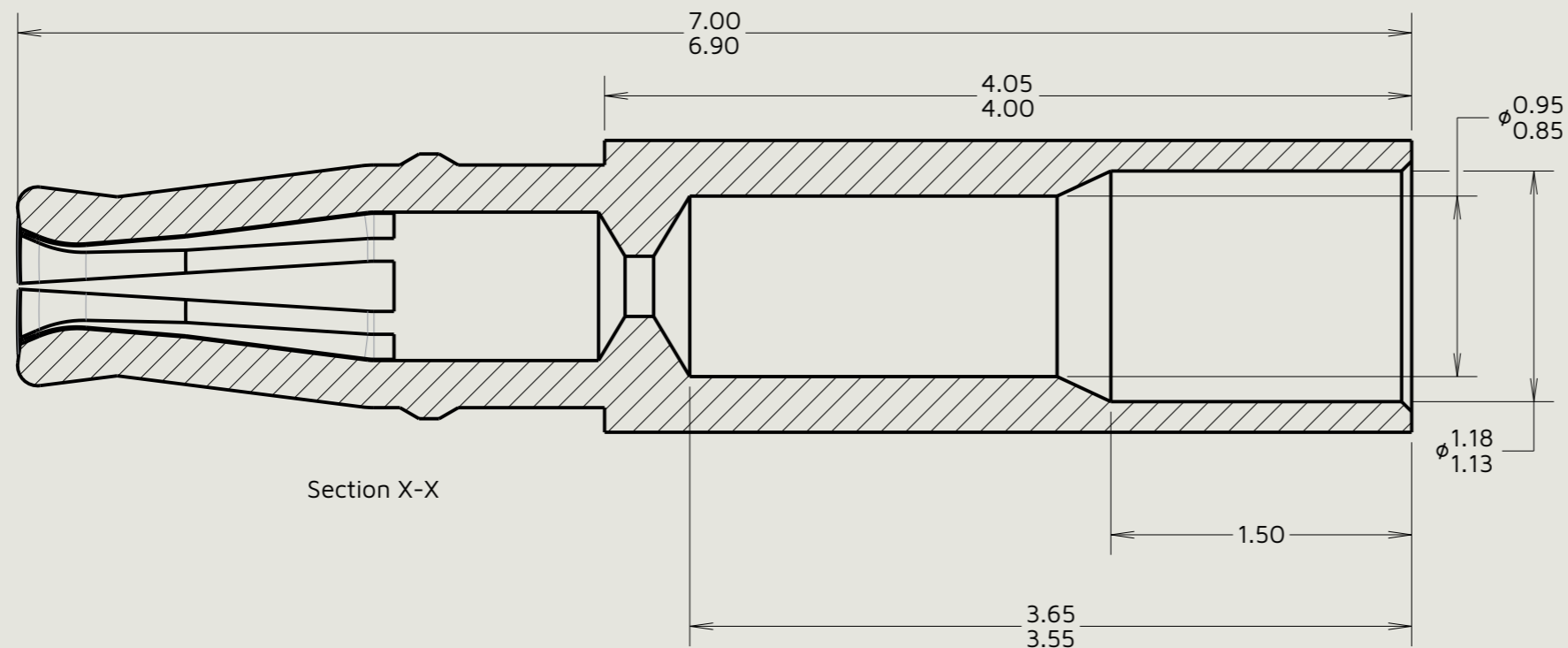

Scale 10:1

Order Code:
M80-20600XX
Finish:
05 - Gold Plated

ES	14	20.03.26	38257
Initials	Rev.	Date	CO
MSP	1	07.04.17	----

Notes:

- Suitable for wire gauge 22 AWG. Maximum insulation ϕ 1.10mm. See Component Specification C049XX (latest issue) for other wire type options. Strip wire by 2.0mm for crimping.
- Recommended hand crimp tool = M22520/2-01 with positioner Z80-444.
- For Crimping Method, see instruction sheet IS-01.
- Patented Technology.

	This drawing and any information or descriptive matter set out hereon are confidential and copyright property of the Harwin group and must not be disclosed, loaned, copied or used for manufacturing, tendering or for any other purpose without their written permission.	TOLERANCES X. = $\pm 0.50\text{mm}$ X.X = $\pm 0.30\text{mm}$ X.XX = $\pm 0.10\text{mm}$ X.XXX = $\pm 0.01\text{mm}$ Angles = $\pm 5^\circ$ Unless stated	Third angle projection 	MATERIAL: See above	Title: Female Crimp T-Contact (22AWG)
		Sheet scale: 30:1 Do not scale Sheet size: A3	FINISH: See above	Drawing number: M80-20600XX	SHT 2 OF 2