

Customer Information Sheet

IF IN DOUBT - ASK

©

NOT TO SCALE

THIRD ANGLE PROJECTION

ALL DIMENSIONS IN mm

SPECIFICATIONS:
MATERIAL:
 HOUSING = GLASS-FILLED PPS,
 UL94V-0, BLACK
 CONTACT = COPPER ALLOY
 JACKSCREW = STAINLESS STEEL
FINISH:
 05 = GOLD ALL OVER
 22 = GOLD ON CONTACT AREA,
 90/10 TIN/LEAD ON TAILS
 42 = GOLD ON CONTACT AREA,
 100% TIN OVER NICKEL ON TAILS
PACKING:
 TUBE
 FOR COMPLETE SPECIFICATION,
 SEE COMPONENT SPECIFICATION
 CO05XX (LATEST ISSUE)

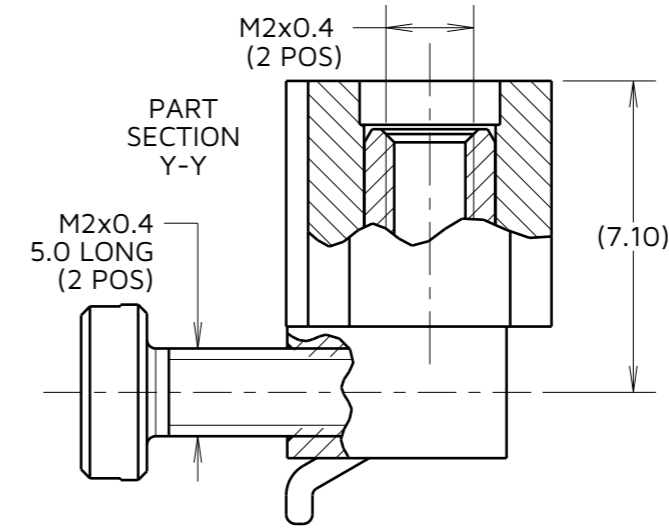
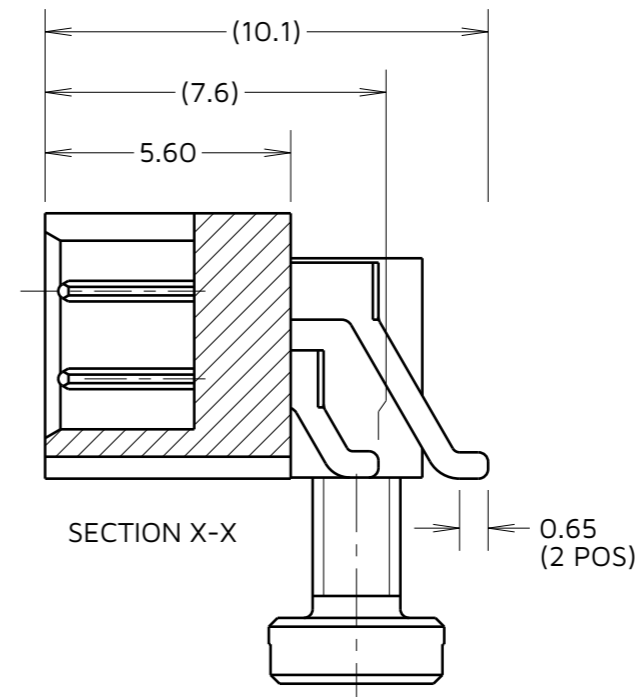
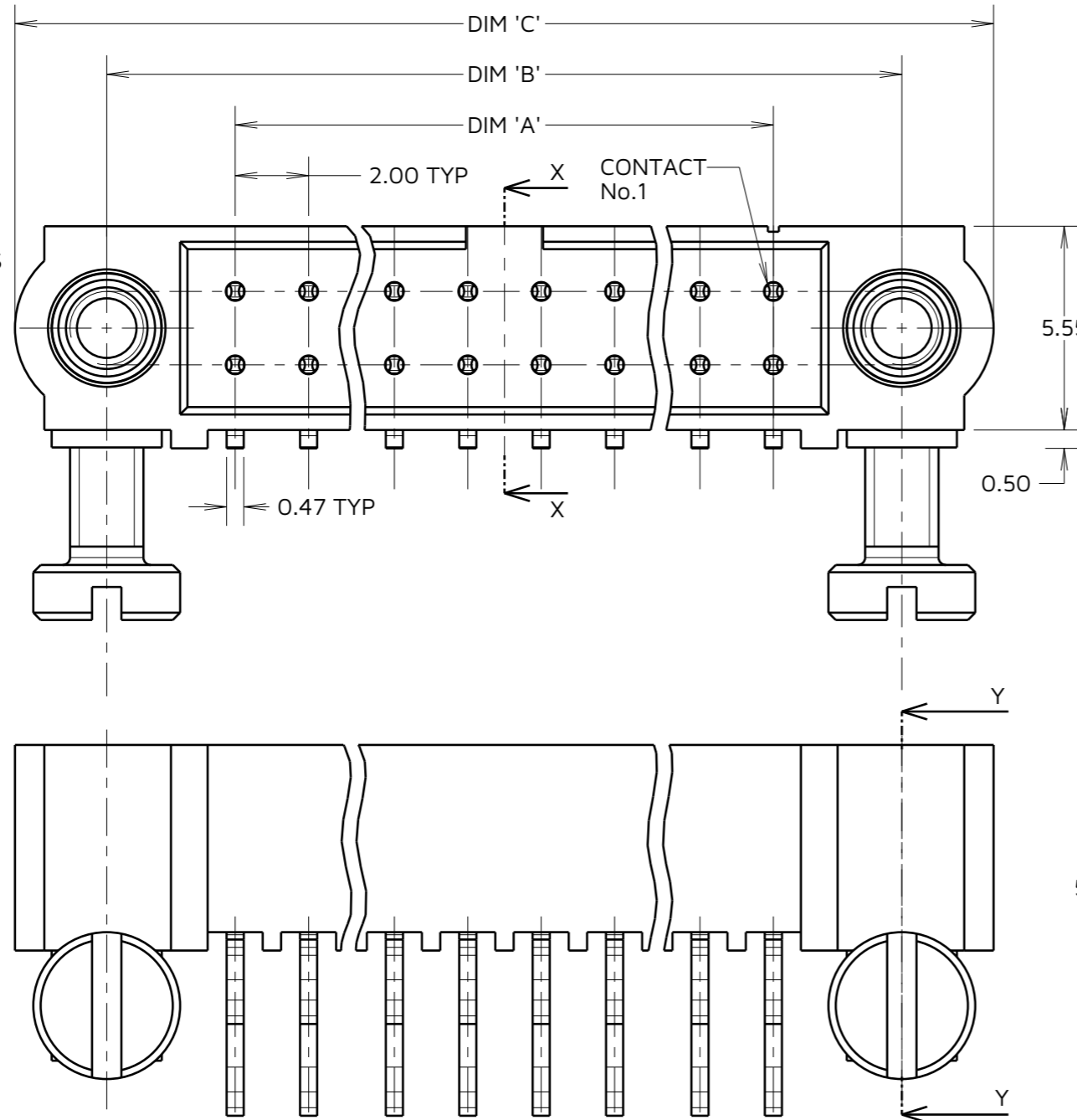
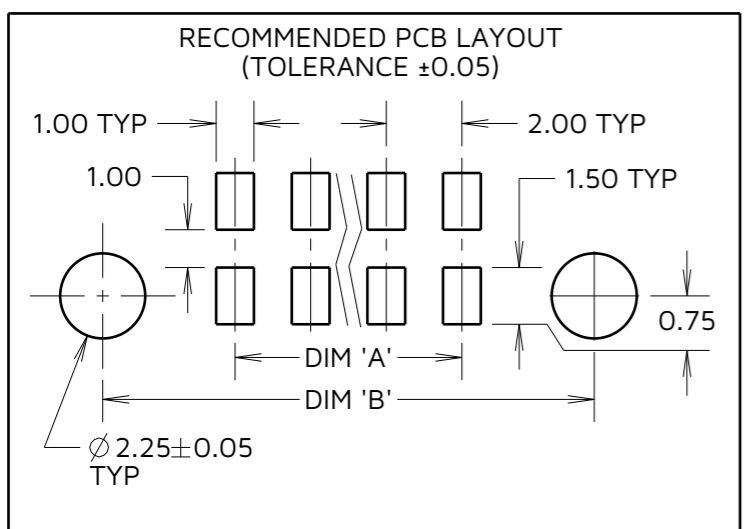

TABLE 1: DIMENSION VARIANTS

PART No.	DIM 'A'	DIM 'B'	DIM 'C'
M80-54304XX	2.00	9.00	14.00
M80-54306XX	4.00	11.00	16.00
M80-54308XX	6.00	13.00	18.00
M80-54310XX	8.00	15.00	20.00
M80-54312XX	10.00	17.00	22.00
M80-54314XX	12.00	19.00	24.00
M80-54316XX	14.00	21.00	26.00
M80-54318XX	16.00	23.00	28.00
M80-54320XX	18.00	25.00	30.00
M80-54322XX	20.00	27.00	32.00
M80-54324XX	22.00	29.00	34.00
M80-54326XX	24.00	31.00	36.00
M80-54328XX	26.00	33.00	38.00
M80-54330XX	28.00	35.00	40.00
M80-54332XX	30.00	37.00	42.00
M80-54334XX	32.00	39.00	44.00
M80-54336XX	34.00	41.00	46.00
M80-54338XX	36.00	43.00	48.00
M80-54340XX	38.00	45.00	50.00
M80-54342XX	40.00	47.00	52.00
M80-54344XX	42.00	49.00	54.00
M80-54346XX	44.00	51.00	56.00
M80-54348XX	46.00	53.00	58.00
M80-54350XX	48.00	55.00	60.00



PRODUCT CODE:
M80-543XXXX

TOTAL No. OF CONTACTS _____
 04 TO 50
 (EVEN NUMBERS ONLY)

FINISH _____
 05 - GOLD
 22 - SELECTIVE GOLD, TIN/LEAD
 42 - SELECTIVE GOLD, 100% TIN OVER NICKEL

MJ	8	06.11.24	34803
NAME	ISS.	DATE	CN/CO
APPROVED: M. JELLEY			
CHECKED: A. YEOMANS			
DRAWN: B. M. KENT			

NOTES:
 1. BOARD MOUNT SCREWS SUPPLIED LOOSE IN A BAG NOT AS SHOWN.

HARWIN
www.harwin.com

TOLERANCES
 X. = ±1mm
 X.X = ±0.50mm
 X.XX = ±0.20mm
 X.XXX = ±0.01mm
 ANGLES = ±5°
 UNLESS STATED

THIS DRAWING AND ANY INFORMATION OR DESCRIPTIVE MATTER SET OUT HEREON ARE CONFIDENTIAL AND COPYRIGHT PROPERTY OF THE HARWIN GROUP AND MUST NOT BE DISCLOSED, LOANED, COPIED OR USED FOR MANUFACTURING, TENDERING OR FOR ANY OTHER PURPOSE WITHOUT THEIR WRITTEN PERMISSION.

MATERIAL & FINISH:
 SEE ABOVE

TITLE: DATAMATE J-TEK DIL
 HORIZ SMT MALE ASSY
 WITH LONG BOARD MOUNT

DRAWING NUMBER: M80-543XXXX

SHT 2 OF 2