

Customer Information Sheet

IF IN DOUBT - ASK

©

NOT TO SCALE

THIRD ANGLE PROJECTION

ALL DIMENSIONS IN mm

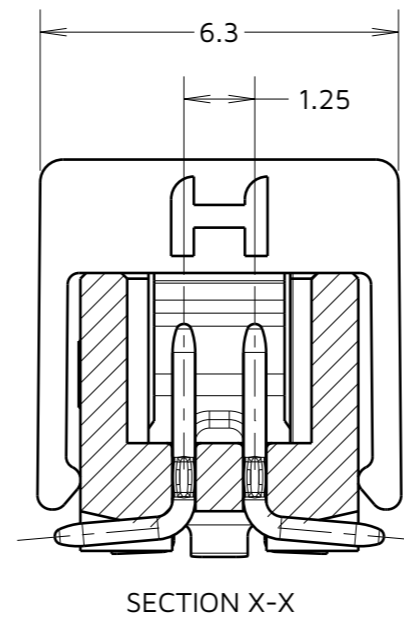
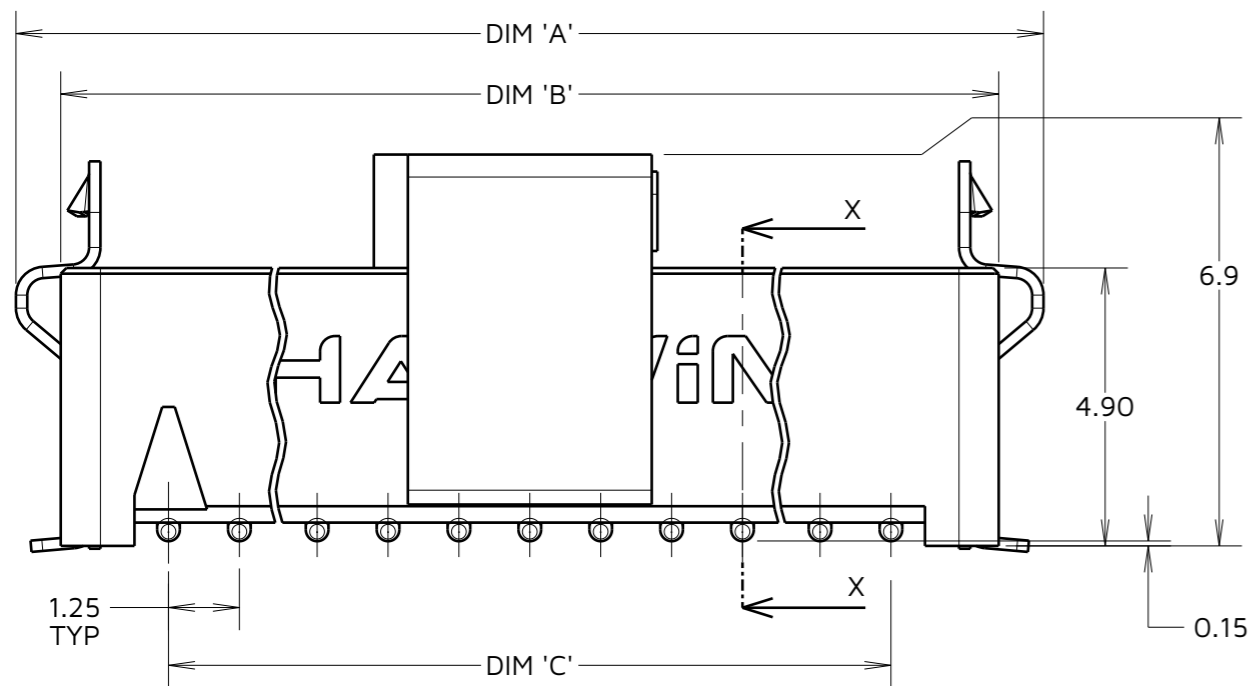
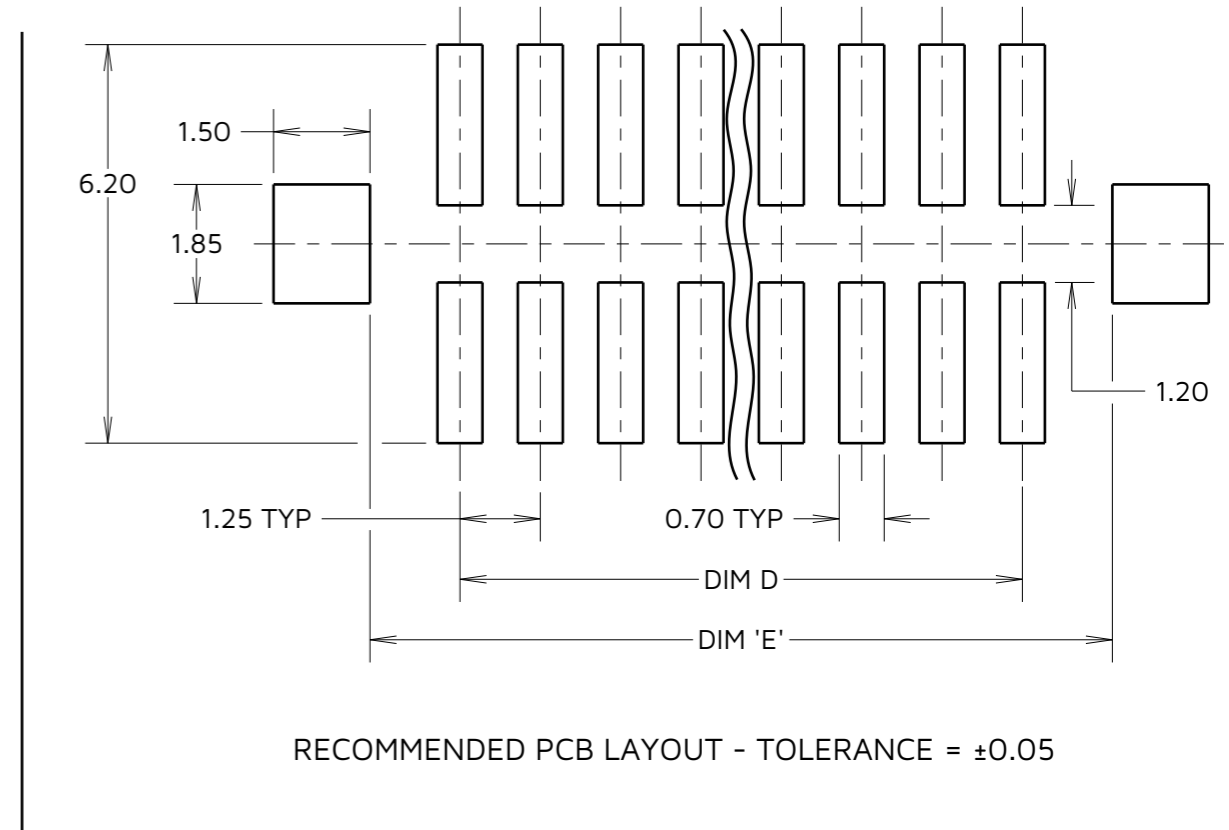
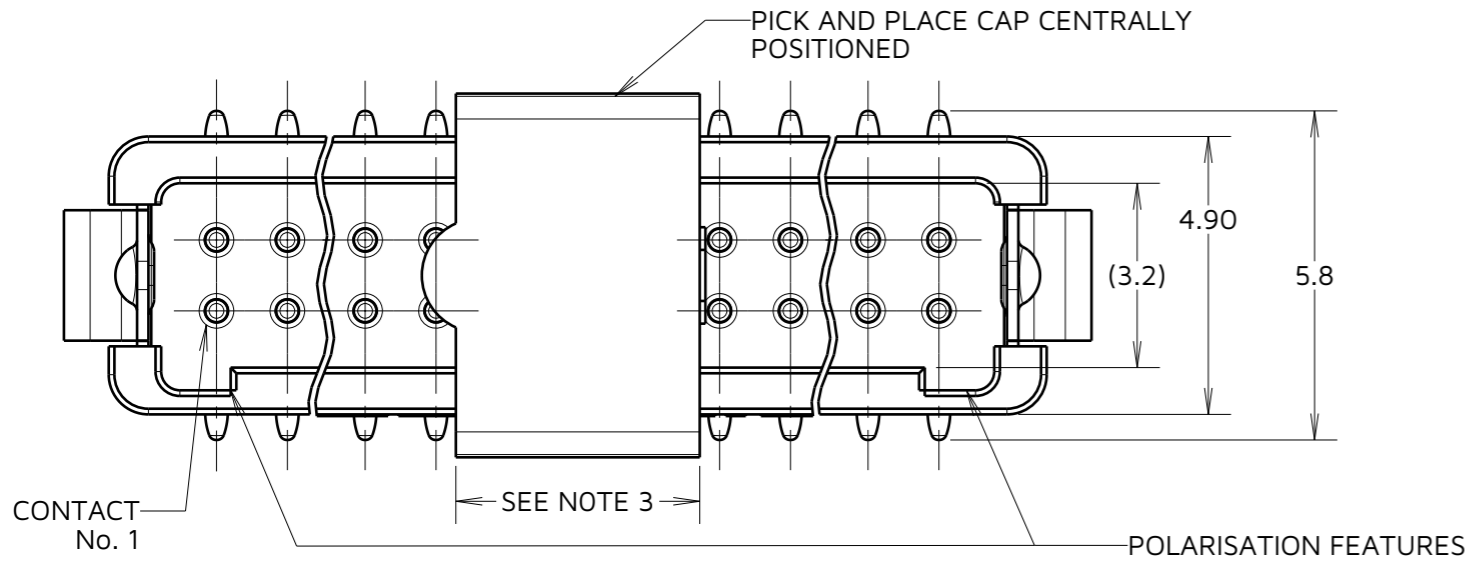

PART No.	DIM 'A'	DIM 'B'	DIM 'C'	DIM 'D'	DIM 'E'
G125-MS10605L3P	7.70	6.30	2.50	2.50	5.00
G125-MS11005L3P	10.20	8.80	5.00	5.00	7.50
G125-MS11205L3P	11.45	10.05	6.25	6.25	8.75
G125-MS11605L3P	13.95	12.55	8.75	8.75	11.25
G125-MS12005L3P	16.45	15.05	11.25	11.25	13.75
G125-MS12605L3P	20.20	18.80	15.00	15.00	17.50
G125-MS13405L3P	25.20	23.80	20.00	20.00	22.50
G125-MS15005L3P	35.20	33.80	30.00	30.00	32.50

CONNECTOR DETAILS
AND PCB LAYOUT ONLY.
SEE SHEET 5
FOR TAPE STRIP DETAILS.

ORDER CODE:
G125-MS1XX05L3P

TOTAL No. OF CONTACTS: _____
06, 10, 12, 16, 20, 26, 34, 50

MJ	9	14.11.24	34985
NAME	ISS.	DATE	CN/CO
APPROVED:		M. JELLEY	
CHECKED:		A. BOXALL	
DRAWN:		S.FLOWER	

NOTES:

- FOR COMPLETE SPECIFICATION, SEE COMPONENT SPECIFICATION C125XX (LATEST ISSUE).
- CO-PLANARITY OF SMT TAILS AND LATCHES TO NOT EXCEED 0.08mm. RECOMMENDED SOLDER PASTE THICKNESS = 0.125mm MIN.
- PICK AND PLACE CAP LENGTH = 4.3mm ON ALL PART NUMBERS EXCEPT G125-MS10605L3P ON THIS PART LENGTH = 3.3mm.

HARWIN

www.harwin.com

TOLERANCES
X. = ±1mm
X.X = ±0.50mm
X.XX = ±0.20mm
X.XXX = ±0.01mm
ANGLES = ±5°
UNLESS STATED

THIS DRAWING AND ANY INFORMATION OR DESCRIPTIVE MATTER SET OUT HEREON ARE CONFIDENTIAL AND COPYRIGHT PROPERTY OF THE HARWIN GROUP AND MUST NOT BE DISCLOSED, LOANED, COPIED OR USED FOR MANUFACTURING, TENDERING OR FOR ANY OTHER PURPOSE WITHOUT THEIR WRITTEN PERMISSION.

MATERIAL & FINISH:

SEE C125XX

TITLE:
1.25mm GECKO MALE VERTICAL SMT CONNECTORS IN TAPE

DRAWING NUMBER: **G125-MS1XX05L3P** 4 OF 5 SHT

Customer Information Sheet

IF IN DOUBT - ASK

©

NOT TO SCALE

THIRD ANGLE PROJECTION

ALL DIMENSIONS IN mm

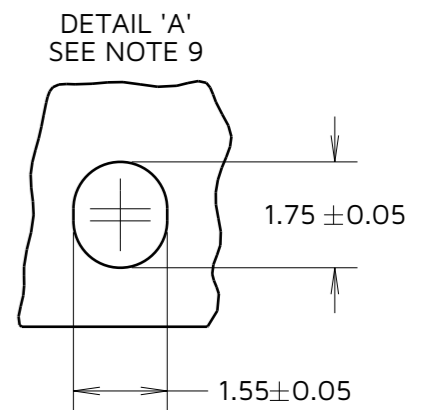
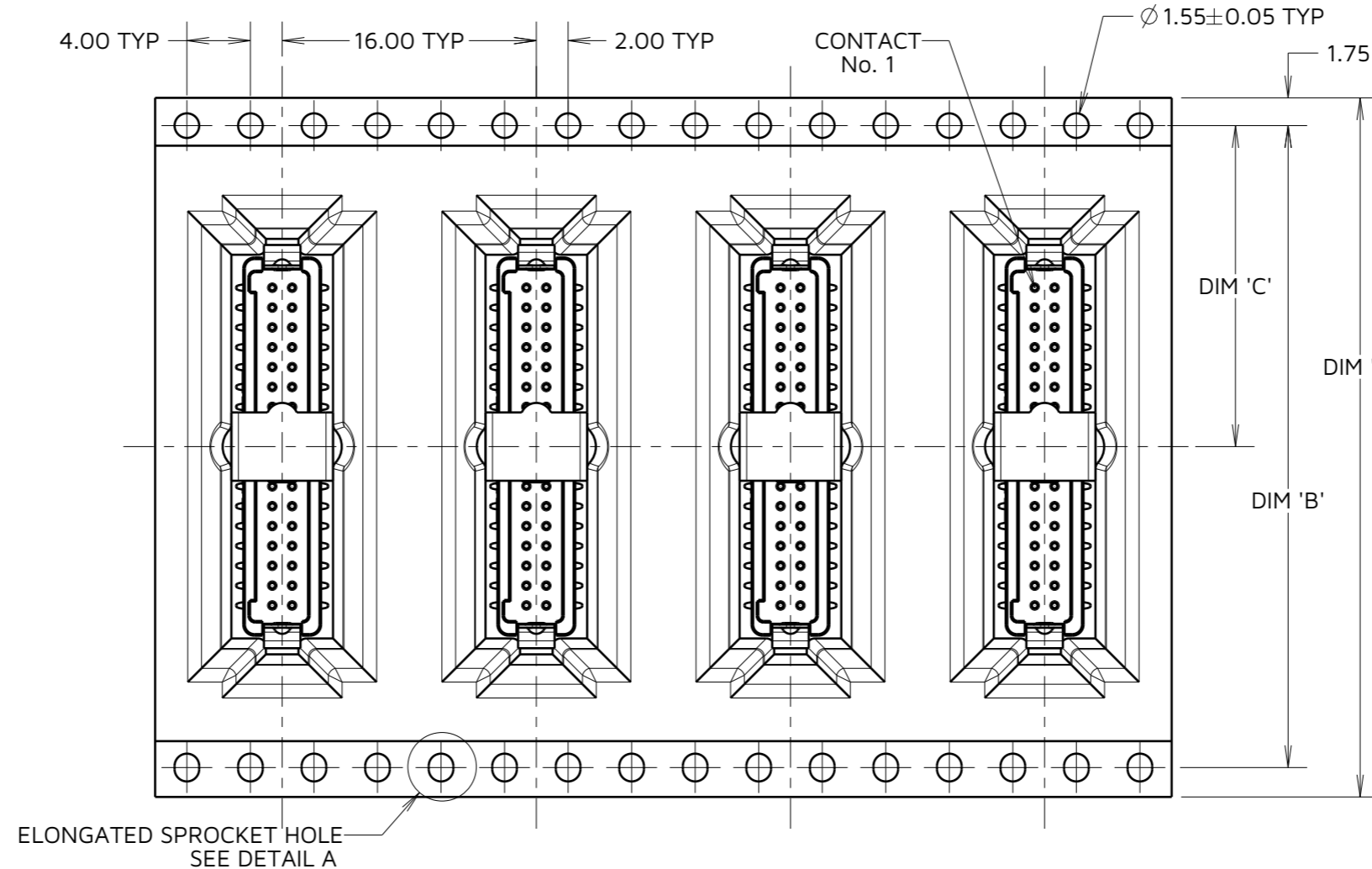
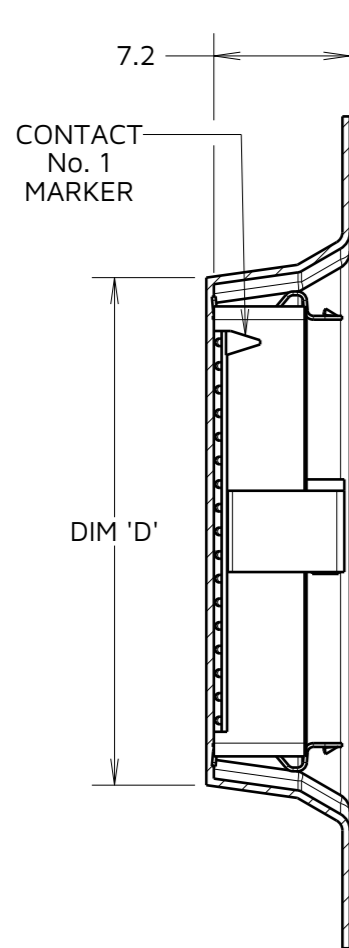

ORDER CODE: **G125-MS1XX05L3P**
 TOTAL No. OF CONTACTS: 06, 10, 12, 16, 20, 26, 34, 50

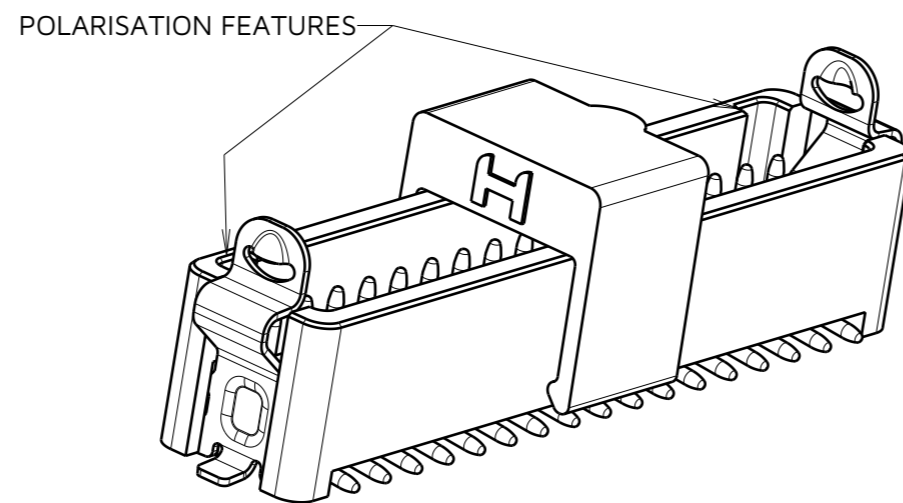

PART No.	DIM 'F'	DIM 'G'	DIM 'H'	(DIM 'I')
G125-MS10605L3P	24.0±0.3	NO ELONGATED HOLE	11.50	(8.6)
G125-MS11005L3P				(11.1)
G125-MS11205L3P	32.0±0.3	28.40	14.20	(12.4)
G125-MS11605L3P				(14.9)
G125-MS12005L3P				(18.1)
G125-MS12605L3P	44.0±0.3	40.40	20.2±0.15	(21.9)
G125-MS13405L3P				(26.9)
G125-MS15005L3P	56.0±0.3	52.40	26.2±0.15	(36.1)

MJ	9	14.11.24	34985
NAME	ISS.	DATE	CN/CO
APPROVED: M. JELLEY			
CHECKED: A. BOXALL			
DRAWN: S.FLOWER			

NOTES:

- COMPONENTS ARE ORIENTED IN TAPE POCKETS AS SHOWN.
- COMPONENTS ARE SUPPLIED IN STRIPS OF 10.
- LARGE QUANTITIES MAY BE SHIPPED ON A REEL AND MAY NOT HAVE A LEADER.
- FOR PARTS ON REEL SUITABLE FOR AUTOMATIC MACHINE PLACEMENT PLEASE ORDER: G125-MS1XX05L3R.
- FOR COMPLETE SPECIFICATION, SEE COMPONENT SPECIFICATION C125XX (LATEST ISSUE).
- COMPONENTS ARE ORIENTATED IN TAPE POCKETS SO THAT THE POLARISING FEATURES ARE FACING AWAY FROM THE FREE END.
- ELONGATED SPROCKET HOLE NOT PRESENT ON 06 & 10 POSITIONS.

HARWIN

www.harwin.com

TOLERANCES
 X. = ±1mm
 X.X = ±0.50mm
 X.XX = ±0.20mm
 X.XXX = ±0.01mm
 ANGLES = ±5°
 UNLESS STATED

THIS DRAWING AND ANY INFORMATION OR DESCRIPTIVE MATTER SET OUT HEREON ARE CONFIDENTIAL AND COPYRIGHT PROPERTY OF THE HARWIN GROUP AND MUST NOT BE DISCLOSED, LOANED, COPIED OR USED FOR MANUFACTURING, TENDERING OR FOR ANY OTHER PURPOSE WITHOUT THEIR WRITTEN PERMISSION.

MATERIAL & FINISH:
 SEE NOTE 8

TITLE: GECKO LATCH MALE VERTICAL SMT CONNECTOR ASSEMBLY

DRAWING NUMBER: G125-MS1XX05L3P

SHT 5 OF 5