

13 December 2024

Dear Customer,

Re: Product change notification for Harwin product.

There has been a change to the M300 range, affecting a visual feature on all male connector housings. The following ranges are affected:

- M300-3240696M1, M300-3241096M1, M300-3250396M1
- M300-3240696M2, M300-3241096M2, M300-3250396M2
- M300-3241096
- M300-MV10345M1, M300- MV30645M1, M300- MV31045M1
- M300-MCXXXXXXXX-XXXXLXX
- M300-MCXXXXXXXX-XXXXXX

We have made a visual edit to some features around the corners of the mating face. These cut-out features were on both sides of the connector, on all 4 corners - they have been removed:

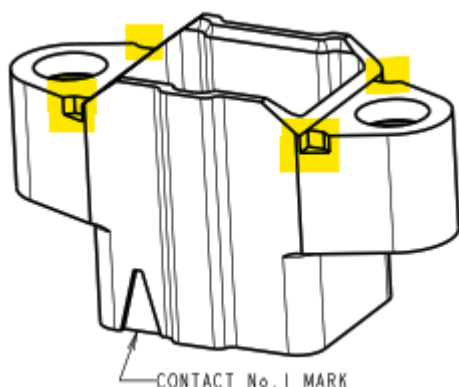

Before the product change

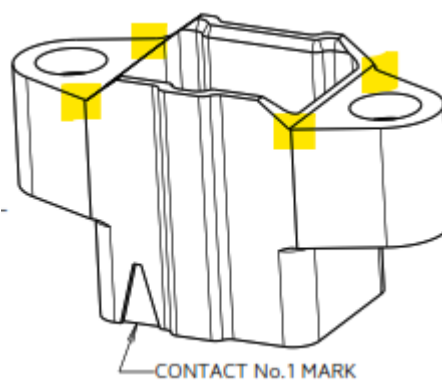

After the product change

HARWIN

The distance from the edge of the shroud to the mating face of the fixings has also been reduced from 1.4mm to 1.2mm nominal (indicated with blue arrows below). The overall dimensions and the mating heights of the connectors are not affected.

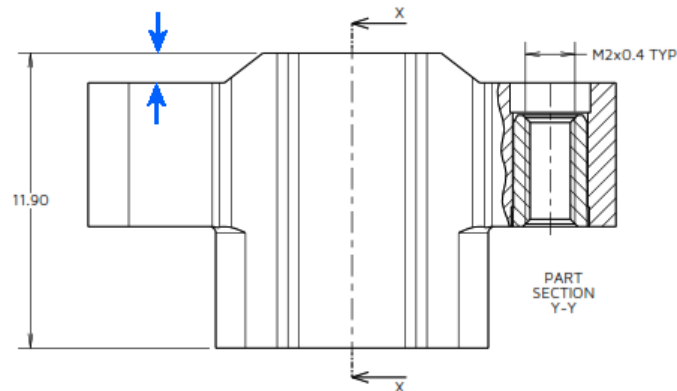

The product replacement will take place over the next few months, as existing stocks of the previous design are exhausted. Once all items are changed, we will not be able to supply product to the previous design.

Technical Drawings and Tracepart CAD models of the housings and PCB connectors fitted with fixings have been revised to the new design. The Technical Drawings for the Cable Assemblies and the M300-3241096 will be revised during January.

If you have any further questions regarding this letter, please do not hesitate to contact us.

Yours faithfully,

The Product Change Team
support@harwin.com