

Customer Information Sheet

IF IN DOUBT - ASK



NOT TO SCALE

THIRD ANGLE PROJECTION

ALL DIMENSIONS IN mm

SPECIFICATION:

MATERIAL:

CONTACT SHELL = BRASS

CONTACT CLIP = BERYLLIUM COPPER

FINISH:

SEE ORDER CODE

FOR ELECTRICAL/MECHANICAL SPECIFICATION

SEE COMPONENT SPECIFICATION C009XX

(LATEST ISSUE)

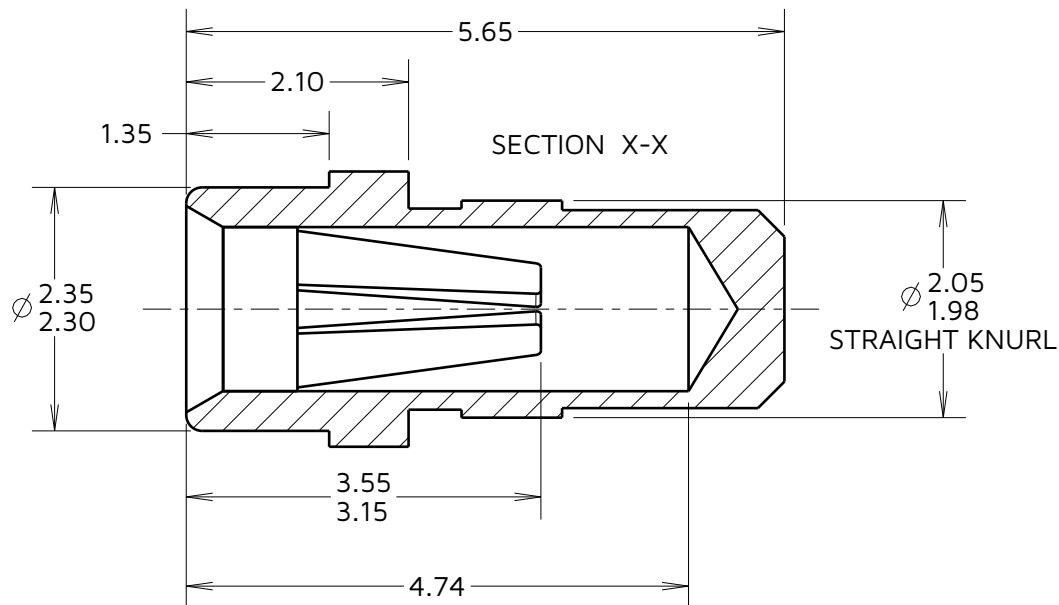
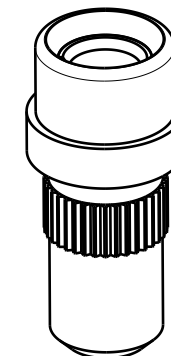

NOTES:

1. RECOMMENDED MOUNTING HOLE SIZE = $\phi 1.96-1.91\text{mm}$.
2. RECOMMENDED PIN SIZE = $\phi 1.05-0.90\text{mm}$.
3. SOCKET MUST BE SOLDERED TO PCB TO ENSURE ELECTRICAL CONNECTION.

ORDER CODE:

H3165-XX

FINISH:

- 01 = TIN SHELL, GOLD CLIP
- 05 = GOLD SHELL, GOLD CLIP
- 46 = 100% TIN SHELL & TIN CLIP

MJ	20	19.08.24	34124
NAME	ISS.	DATE	CN/CO
APPROVED:		M. JELLEY	
CHECKED:		R. ALEXANDER	
DRAWN:		I. SANDY	

HARWIN

www.harwin.com

TOLERANCES

- X. = $\pm 1\text{mm}$
- X.X = $\pm 0.50\text{mm}$
- X.XX = $\pm 0.20\text{mm}$
- X.XXX = $\pm 0.01\text{mm}$

ANGLES = $\pm 5^\circ$
UNLESS STATED

THIS DRAWING AND ANY INFORMATION OR DESCRIPTIVE MATTER SET OUT HEREON ARE CONFIDENTIAL AND COPYRIGHT PROPERTY OF THE HARWIN GROUP AND MUST NOT BE DISCLOSED, LOANED, COPIED OR USED FOR MANUFACTURING, TENDERING OR FOR ANY OTHER PURPOSE WITHOUT THEIR WRITTEN PERMISSION.

MATERIAL & FINISH:

SEE ABOVE

TITLE:

SOCKET ASSEMBLY FOR
 $\phi 1.00\text{mm}$ PIN

DRAWING NUMBER:

H3165-XX

SHT
2
OF 2