

# Customer Information Sheet

IF IN DOUBT - ASK



NOT TO SCALE

THIRD ANGLE PROJECTION

ALL DIMENSIONS IN mm

PART No.	DIM 'A'	DIM 'B'	DIM 'C'	(DIM 'D')	(DIM 'E')	DIM 'F'	DIM 'G'
M55-3000242R	7.56	6.29	5.52	4.38	3.38	5.69	1.27
M55-3000342R	8.83	7.54	6.79	5.65	4.65	6.96	2.54
M55-3000442R	10.10	8.82	8.06	6.92	5.92	8.23	3.81
M55-3000642R	12.64	11.37	10.60	9.46	8.46	10.77	6.35
M55-3000842R	15.18	13.89	13.14	12.00	11.00	13.31	8.89
M55-3001042R	17.72	16.43	15.68	14.54	13.54	15.85	11.43
M55-3001242R	20.26	18.99	18.22	17.08	16.08	18.39	13.97

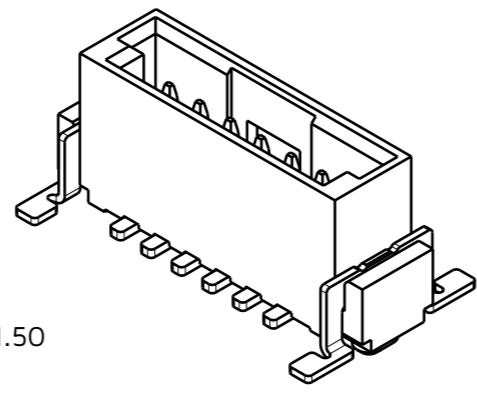
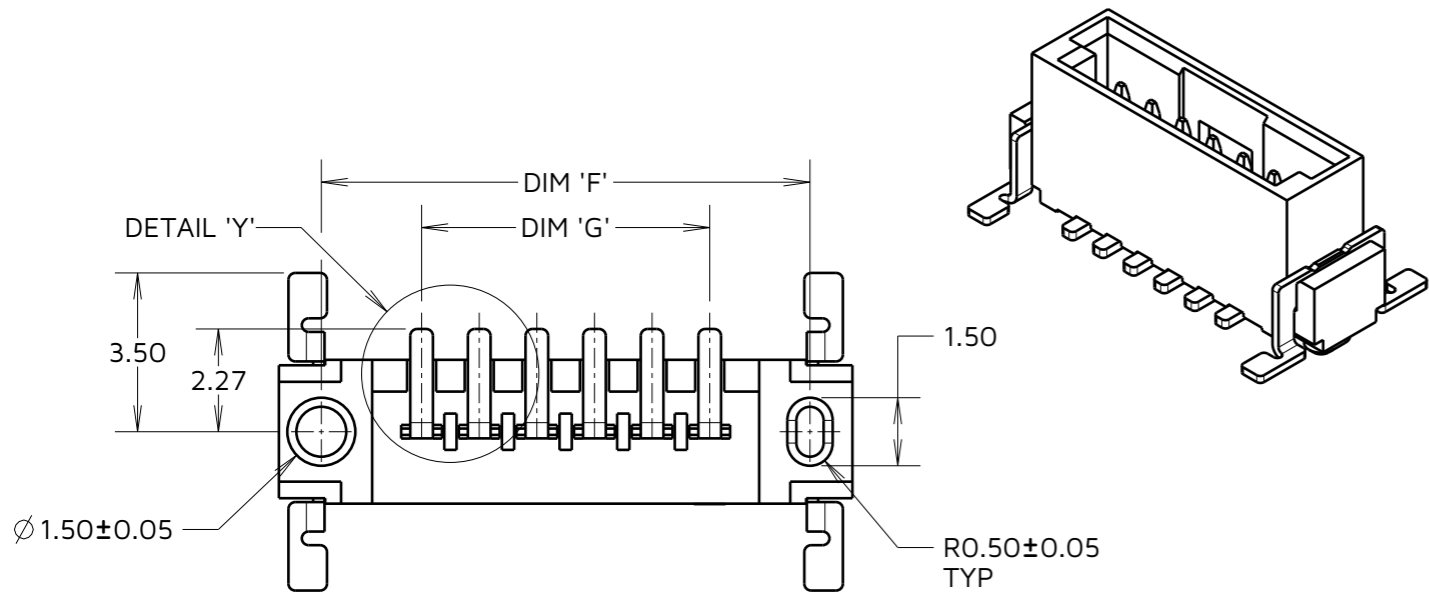

**SPECIFICATIONS:**  
**MATERIAL:**  
 HOUSING = HIGH TEMP, PA9T, UL94V-0  
 CONTACT = COPPER ALLOY  
 RETAINING STRAP = BRASS  
**PLATING:**  
 CONTACT = GOLD OVER NICKEL ON CONTACT AREA,  
 TIN OVER NICKEL ON TAILS  
 RETAINING STRAP = TIN OVER NICKEL  
**PACKING:**  
 TAPE & REEL

**ORDER CODE:**  
**M55-300XX42R**  
 TOTAL No. OF CONTACTS  
 02, 03, 04, 06, 08, 10, 12

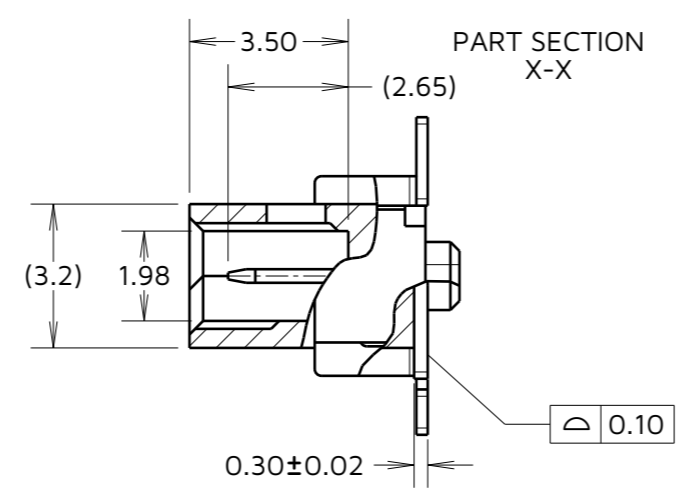
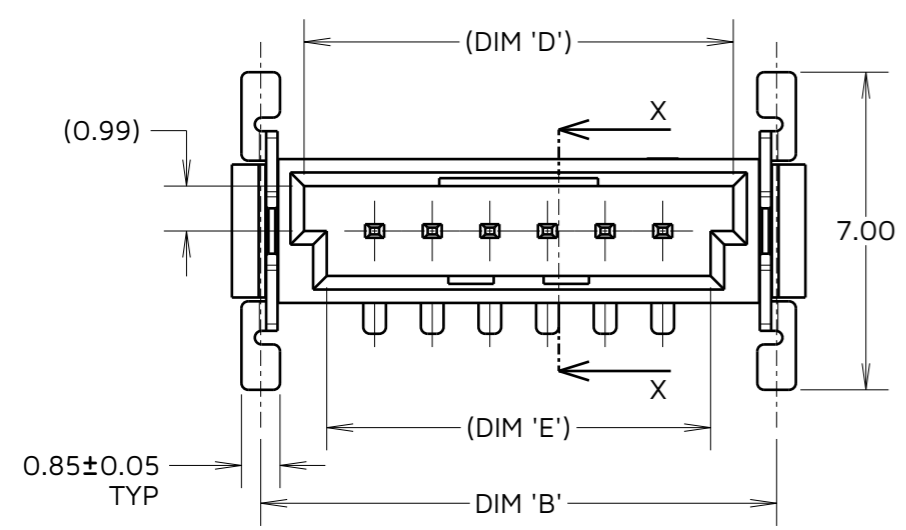
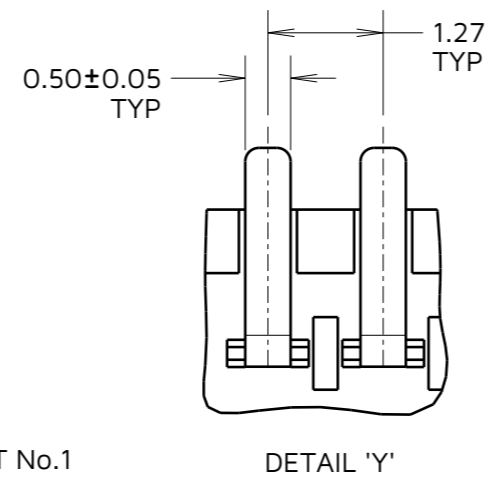
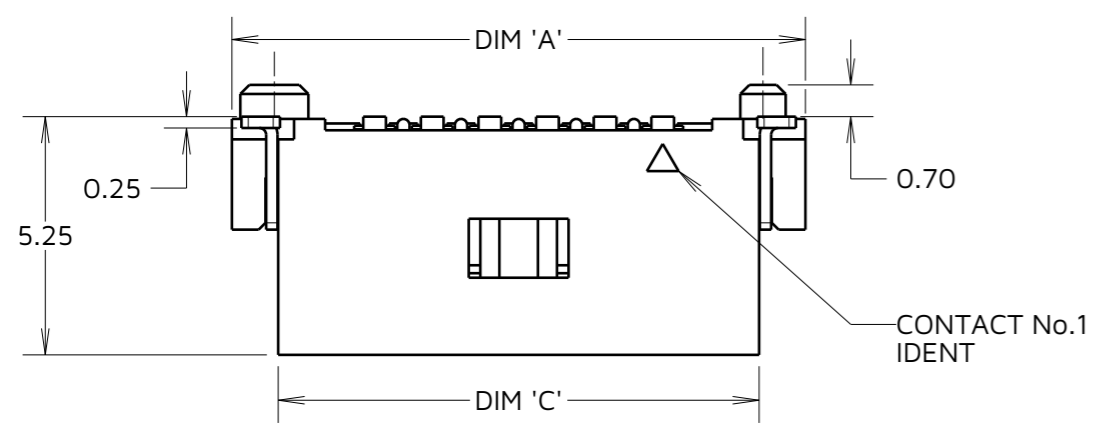

FOR COMPLETE SPECIFICATION, SEE COMPONENT SPECIFICATION C047XX (LATEST ISSUE)

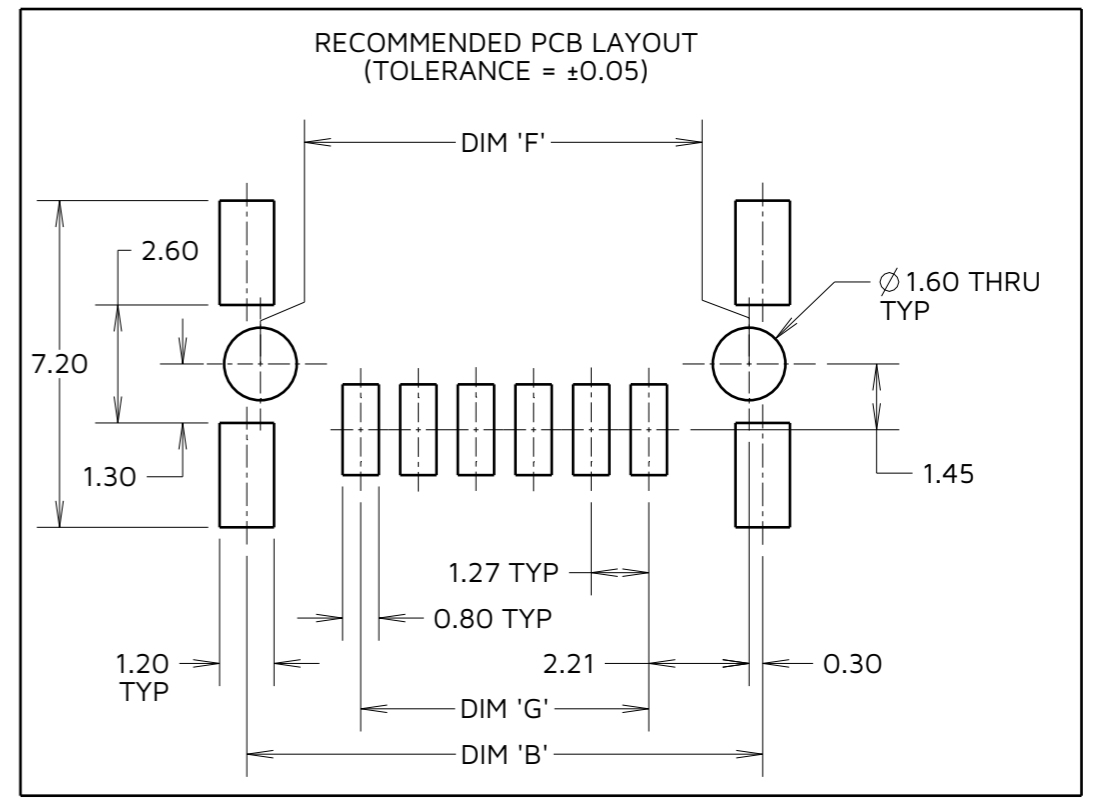

**NOTES:**  
 1. FOR TAPE AND REEL DETAILS SEE SHEET 4.  
 2. ALL TOLERANCES ARE ±0.20, UNLESS OTHERWISE STATED.



**TOLERANCES**  
 X. = ±1mm  
 X.X = ±0.50mm  
 X.XX = ±0.20mm  
 X.XXX = ±0.01mm  
 ANGLES = ±5°  
 UNLESS STATED

THIS DRAWING AND ANY INFORMATION OR DESCRIPTIVE MATTER SET OUT HEREON ARE CONFIDENTIAL AND COPYRIGHT PROPERTY OF THE HARWIN GROUP AND MUST NOT BE DISCLOSED, LOANED, COPIED OR USED FOR MANUFACTURING, TENDERING OR FOR ANY OTHER PURPOSE WITHOUT THEIR WRITTEN PERMISSION.

**MATERIAL & FINISH:**  
 SEE ABOVE

**TITLE:** KONTROL 1.27mm PITCH VERTICAL MALE SIL ASSEMBLY  
**DRAWING NUMBER:** M55-300XX42R

RA	1	21.10.24	34909
NAME	ISS.	DATE	CN/CO
APPROVED:		A.BOXALL	
CHECKED:		A.YEOMANS	
DRAWN:		R.ALEXANDER	

# Customer Information Sheet

IF IN DOUBT - ASK

©

NOT TO SCALE

THIRD ANGLE PROJECTION

ALL DIMENSIONS IN mm

TAPE DETAILS FOR 2 TO 6 CONTACT CONNECTORS

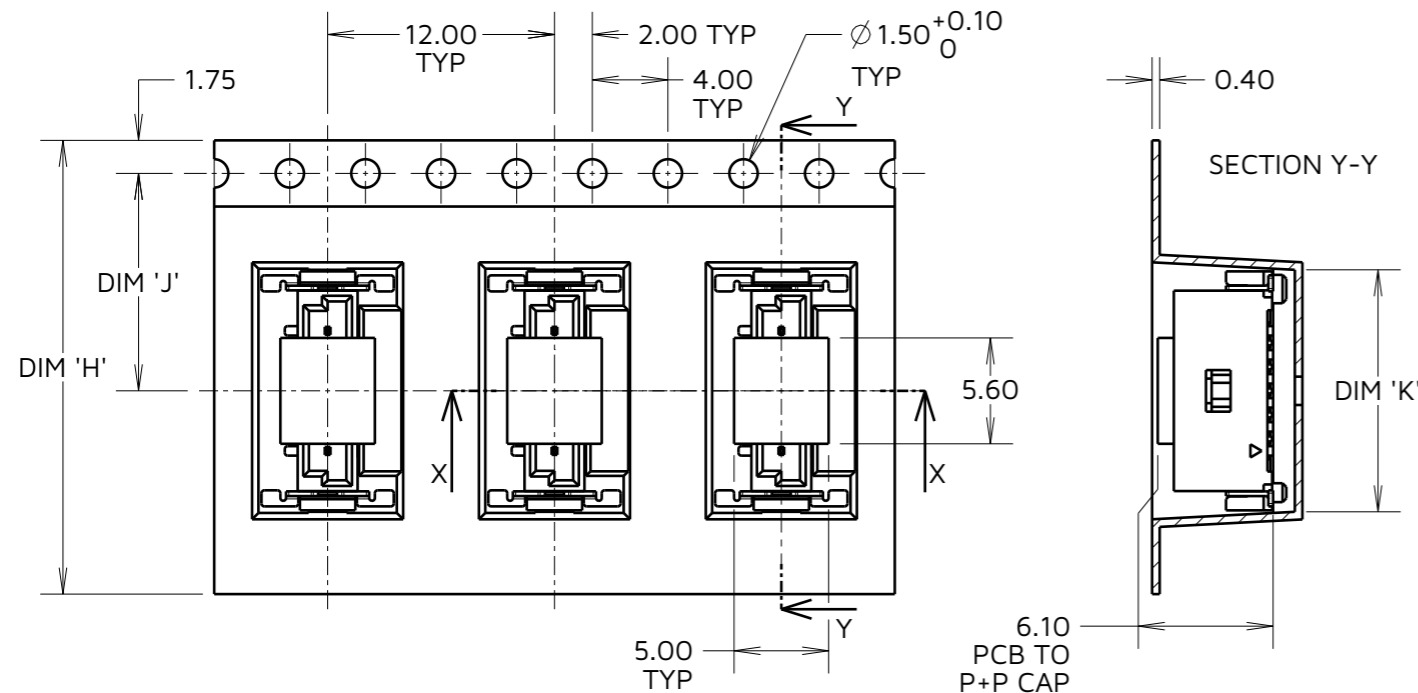

TAPE DETAILS FOR 8 TO 12 CONTACT CONNECTORS

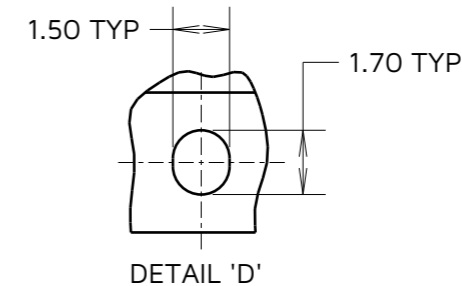
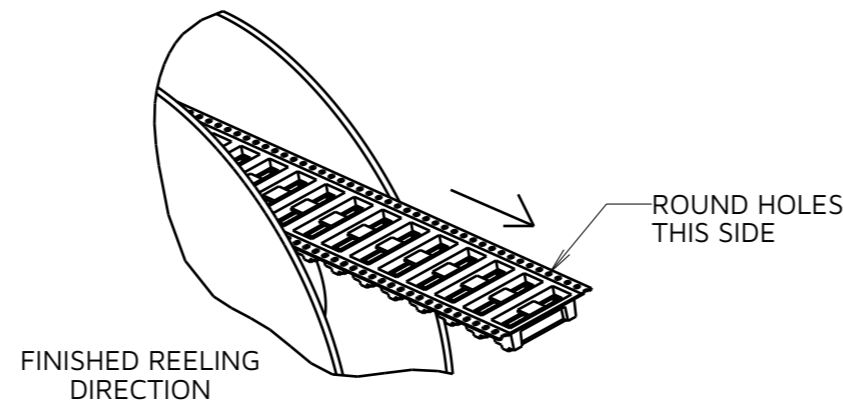
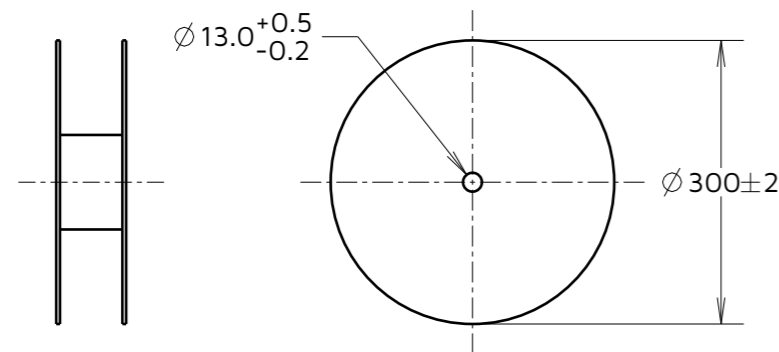
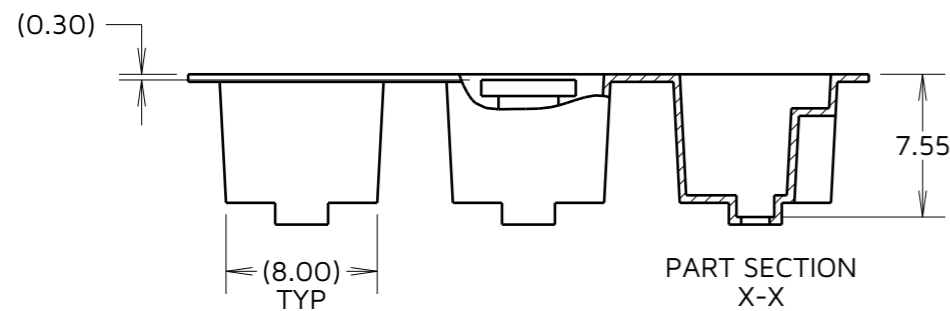
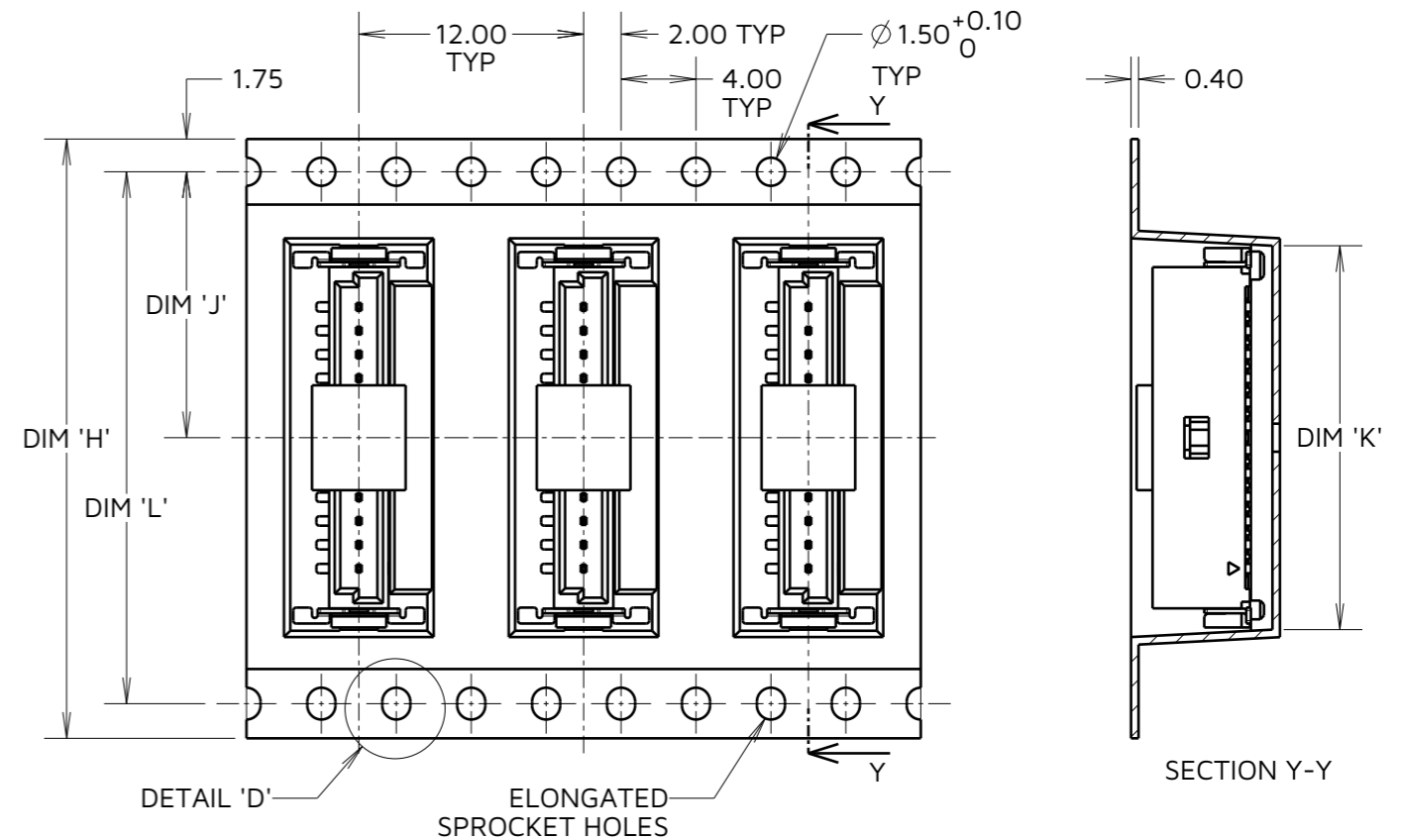

ORDER CODE:  
**M55-300XX42R**  
TOTAL No. OF CONTACTS  
02, 03, 04, 06, 08, 10, 12

TABLE 2: PACKING TAPE DETAILS

PART No.	DIMENSIONS				PACK QTY
	DIM 'H'	DIM 'J'	DIM 'K'	DIM 'L'	
M55-3000242R	24.00	11.50	7.8	-	600
M55-3000342R	24.00	11.50	9.8	-	600
M55-3000442R	24.00	11.50	11.1	-	600
M55-3000642R	24.00	11.50	12.8	-	600
M55-3000842R	32.00	14.20	16.2	28.40	600
M55-3001042R	32.00	14.20	18.7	28.40	600
M55-3001242R	32.00	14.20	20.5	28.40	600

RA	1	21.10.24	34909
NAME	ISS.	DATE	CN/CO
APPROVED:		A.BOXALL	
CHECKED:		A.YEOMANS	
DRAWN:		R.ALEXANDER	

- NOTES:  
3. PRODUCT TAPE AND REELED IN GENERAL ACCORDANCE WITH EIA-481 (ELECTRICAL INDUSTRIES ASSOCIATION).  
4. FOR COMPONENT LEVEL DETAILS SEE SHEET 3.

**HARWIN**

www.harwin.com

TOLERANCES  
X. = ±1mm  
X.X = ±0.50mm  
X.XX = ±0.20mm  
X.XXX = ±0.01mm  
ANGLES = ±5°  
UNLESS STATED

THIS DRAWING AND ANY INFORMATION OR DESCRIPTIVE MATTER SET OUT HEREON ARE CONFIDENTIAL AND COPYRIGHT PROPERTY OF THE HARWIN GROUP AND MUST NOT BE DISCLOSED, LOANED, COPIED OR USED FOR MANUFACTURING, TENDERING OR FOR ANY OTHER PURPOSE WITHOUT THEIR WRITTEN PERMISSION.

MATERIAL & FINISH:  
SEE SHEET 3

TITLE: **KONTROL 1.27mm PITCH VERTICAL MALE SIL ASSEMBLY**

DRAWING NUMBER:  
**M55-300XX42R**

SHT  
4 OF  
4